

4A 1500V N-channel Enhancement Mode Power MOSFET

1 Description

DH4N150, the silicon N-channel Enhanced VDMOSFETs, is obtained by the self-aligned planar Technology which reduce the conduction loss, improve switching performance and enhance the avalanche energy. The transistor can be used in various power switching circuit for system miniaturization and higher efficiency. The package form is TO-3PF, which accords with the RoHS standard.

2 Features

- Fast Switching
- Low ON Resistance($R_{dson} \leq 6.5\Omega$)
- Low Gate Charge (Typical Data: 38nC)
- Low Reverse transfer capacitances(Typical:2.9pF)
- 100% Single Pulse avalanche energy Test

3 Applications

- Power switch circuit of adaptor and charger.

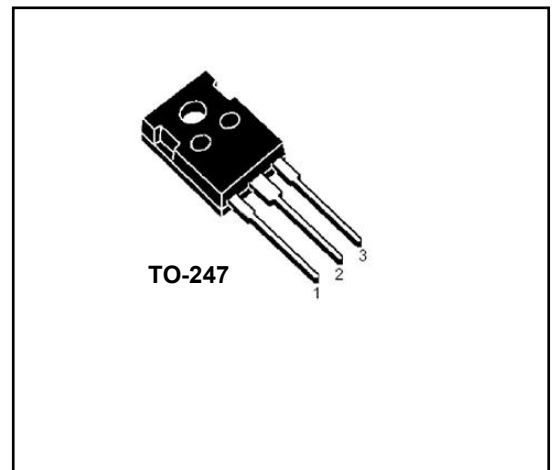
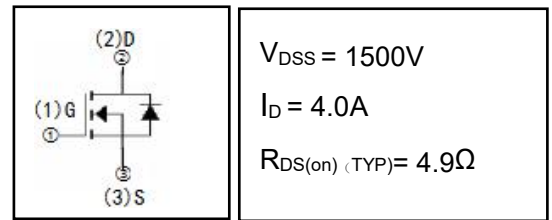

4 Electrical Characteristics

4.1 Absolute Maximum Ratings (Tc=25°C, unless otherwise noted)

PARAMETER	SYMBOL	VALUE	UNIT	
Drain-Source Voltage	V_{DS}	1500	V	
Gate-Source Voltage	V_{GS}	± 30	V	
Drain Current(continuous) ^(Note 3)	I_D	4.0	A	
Drain Current(continuous)(T=100°C) ^(Note 3)	I_D	2.0	A	
Drain Current(Pulsed)	I_{DM}	16	A	
Single Pulse Avalanche Energy ^(Note 4)	E_{AS}	227	mJ	
Maximum Power Dissipation	$T_a=25^\circ C$	P_{tot}	1.85	W
	$T_c=25^\circ C$	P_{tot}	230	W
Operating Junction Temperature Range	T_j	-55~150	°C	
Storage Temperature Range	T_{stg}	-55~150	°C	
High Temperature(tin solder)	T_L	300	°C	

4.2 Thermal Characteristics

PARAMETER	SYMBOL	VALUE	UNIT
Thermal Resistance, Junction to Case-sink	R_{thJC}	0.54	°C/W
Thermal Resistance, Junction to Ambient	R_{thJA}	40	°C/W

4.3 Electrical Characteristics (Tc=25°C, unless otherwise noted)

PARAMETER	SYMBOL	Test Condition	VALUE			UNIT
			MIN	TYP	MAX	
Off Characteristics						
Drain-source Breakdown Voltage	BV _{DSS}	I _D =250μA, V _{GS} =0V	1500	--	--	V
Zero Gate Voltage Drain Current	I _{DSS}	V _{DS} =1500V, V _{GS} =0V, T _C =25°C	--	--	25	μA
		V _{DS} =1200V, V _{GS} =0V, T _C =125°C	--	--	500	μA
Gate-to-Body Leakage Current	I _{GSS}	V _{GS} =±30V, V _{DS} =0V	--	--	±100	nA
On Characteristics (Note 3)						
Gate threshold voltage	V _{GS(th)}	V _{DS} =V _{GS} , I _D =250μA	3.0	--	5.0	V
Drain-source on Resistance	R _{DS(on)}	V _{GS} =10V, I _D =2.0A	--	4.9	6.5	Ω
Dynamic Characteristics						
Input Capacitance	C _{iss}	V _{GS} =0V, V _{DS} =25V, f=1.0MHz	--	2050	--	pF
Output Capacitance	C _{oss}		--	98	--	
Reverse Transfer Capacitance	C _{rss}		--	2.9	--	
Turn-on Delay Time	T _{d(on)}	I _D =4A, V _{DD} =750V, V _{GS} =10V, R _G =10Ω	--	36	--	ns
Turn-on Rise Time	t _r		--	20	--	
Turn-off Delay Time	T _{d(off)}		--	56	--	
Turn-off Fall	t _f		--	32	--	
Total Gate Charge	Q _g	I _D =4A, V _{DD} =750V, V _{GS} =10V	--	38	--	nc
Gate-to-Source Charge	Q _{gs}		--	10	--	
Gate-to-Drain("Miller")C harge	Q _{gd}		--	15	--	
Drain-Source Diode Characteristics						
Diode Forward Voltage ^(Note 3)	V _{FSD}	V _{GS} =0V, I _S =4A	--	--	1.5	V
Continuous Source Current (BodyDiode) ^(Note 3)	I _S		--	--	4	A
Reverse Recovery Time	t _{rr}	T _J =25°C, I _F =4A, dI _F /dt=100A/μS, V _{GS} =0V	--	882	--	us
Reverse Recovery Charge	Q _{rr}		--	6.5	--	uc

Notes:

- 1: Repetitive rating, pulse width limited by maximum junction temperature.
- 2: Surface mounted on FR4 Board, t_s≤10sec.
- 3: Pulse width ≤ 300μs, duty cycle ≤ 2%.
- 4: L=10 mH, I_D=6.7A, V_{DD}=50V, Start T_J=25°C.

5 Typical Test Circuit and Waveform

<p style="text-align: center;">Gate Charge Test Circuit</p>	<p style="text-align: center;">Gate Charge Waveforms</p>
<p style="text-align: center;">Resistive Switching Test Circuit</p>	<p style="text-align: center;">Resistive Switching Waveforms</p>
<p style="text-align: center;">Diode Reverse Recovery Test Circuit</p>	<p style="text-align: center;">Diode Reverse Recovery Waveform</p>

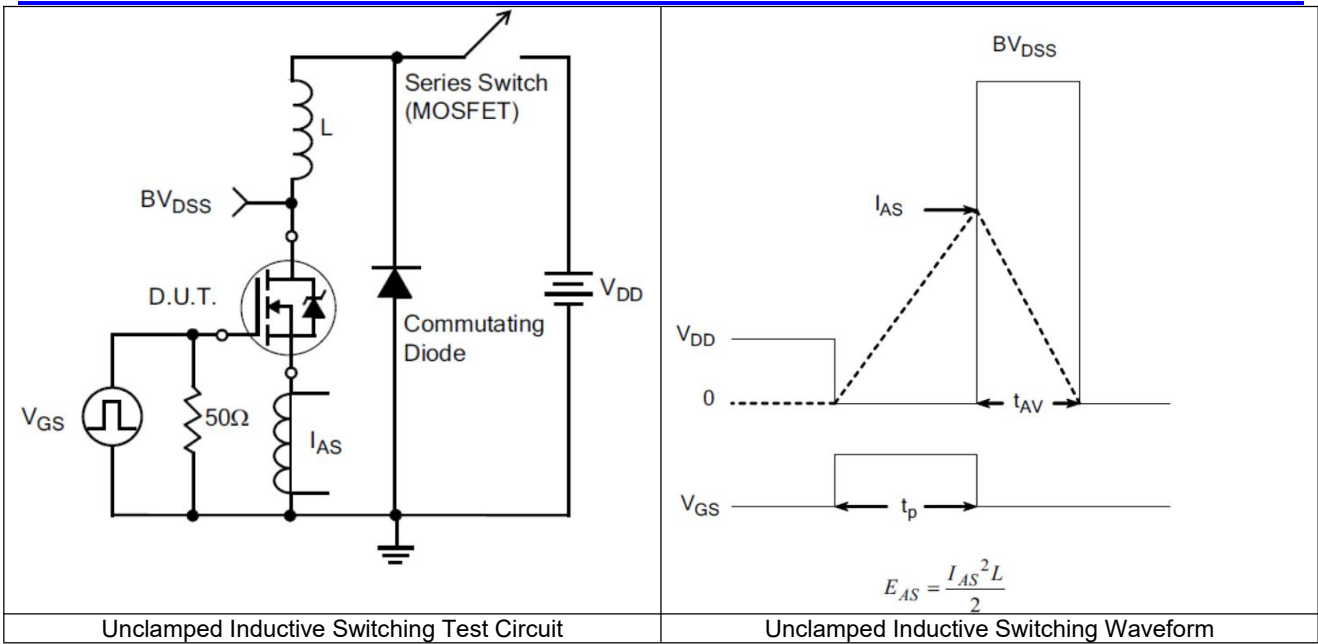

Unclamped Inductive Switching Test Circuit

Unclamped Inductive Switching Waveform

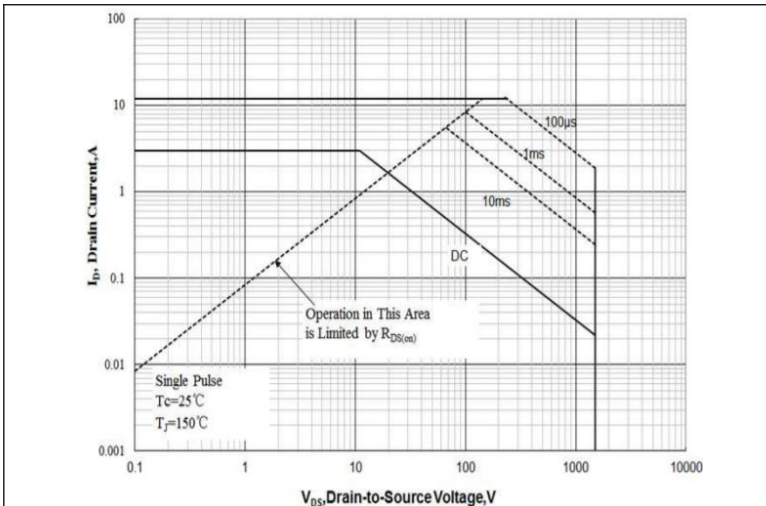

Maximum Forward Bias Safe Operating Area

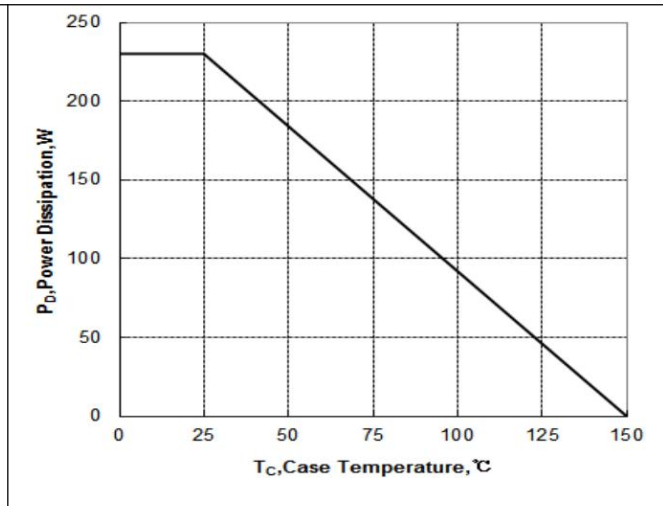

Maximum Power dissipation vs Case Temperature

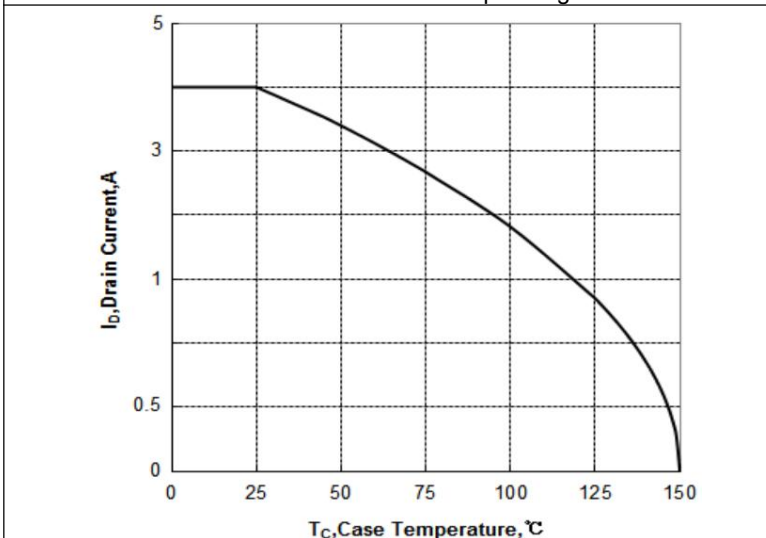

Maximum Continuous Drain Current vs Case Temperature

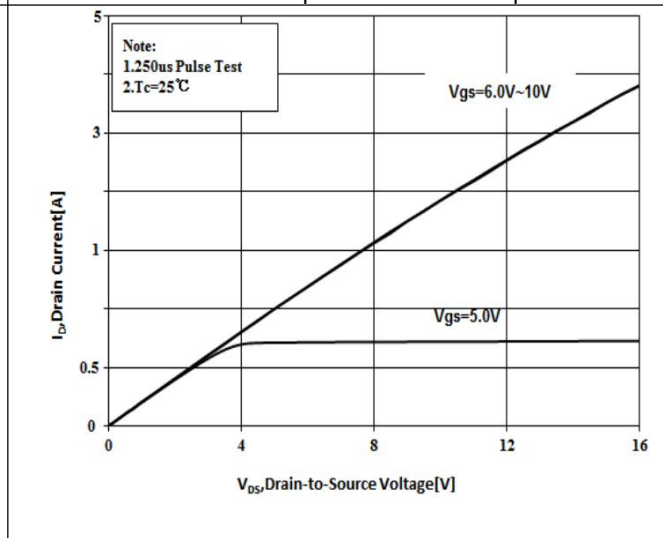

Typical Output Characteristics

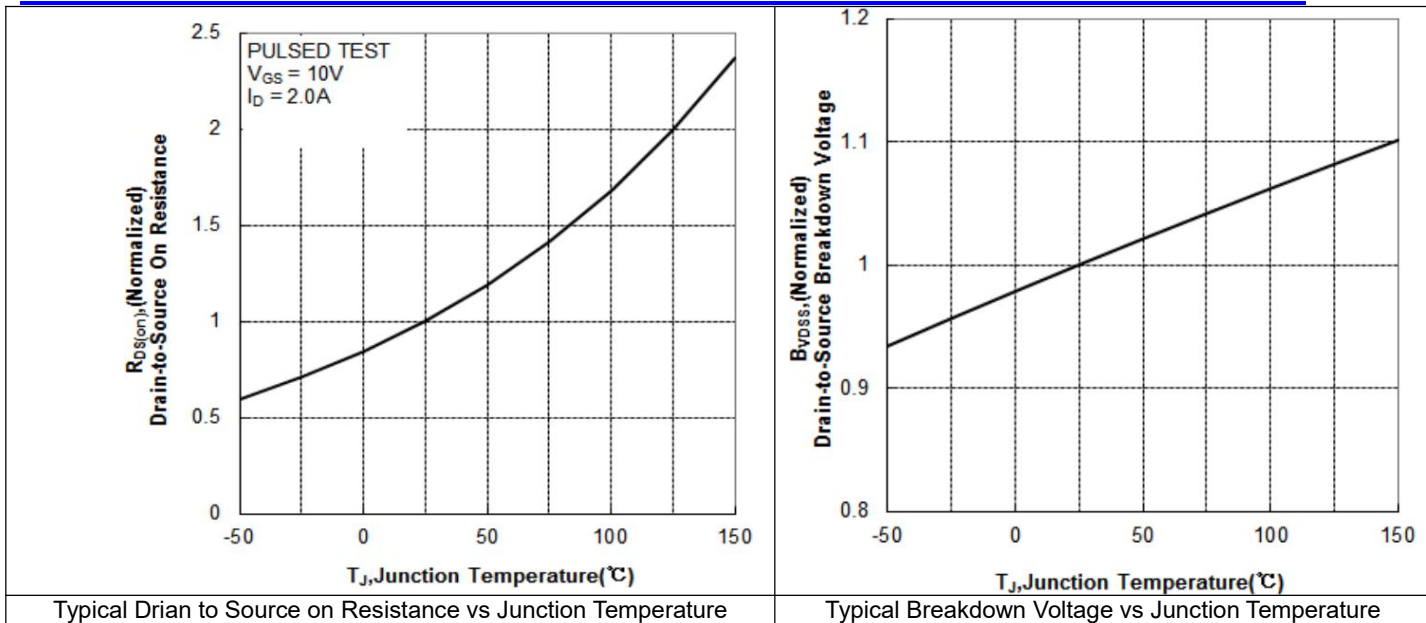

7 Product Names Rules

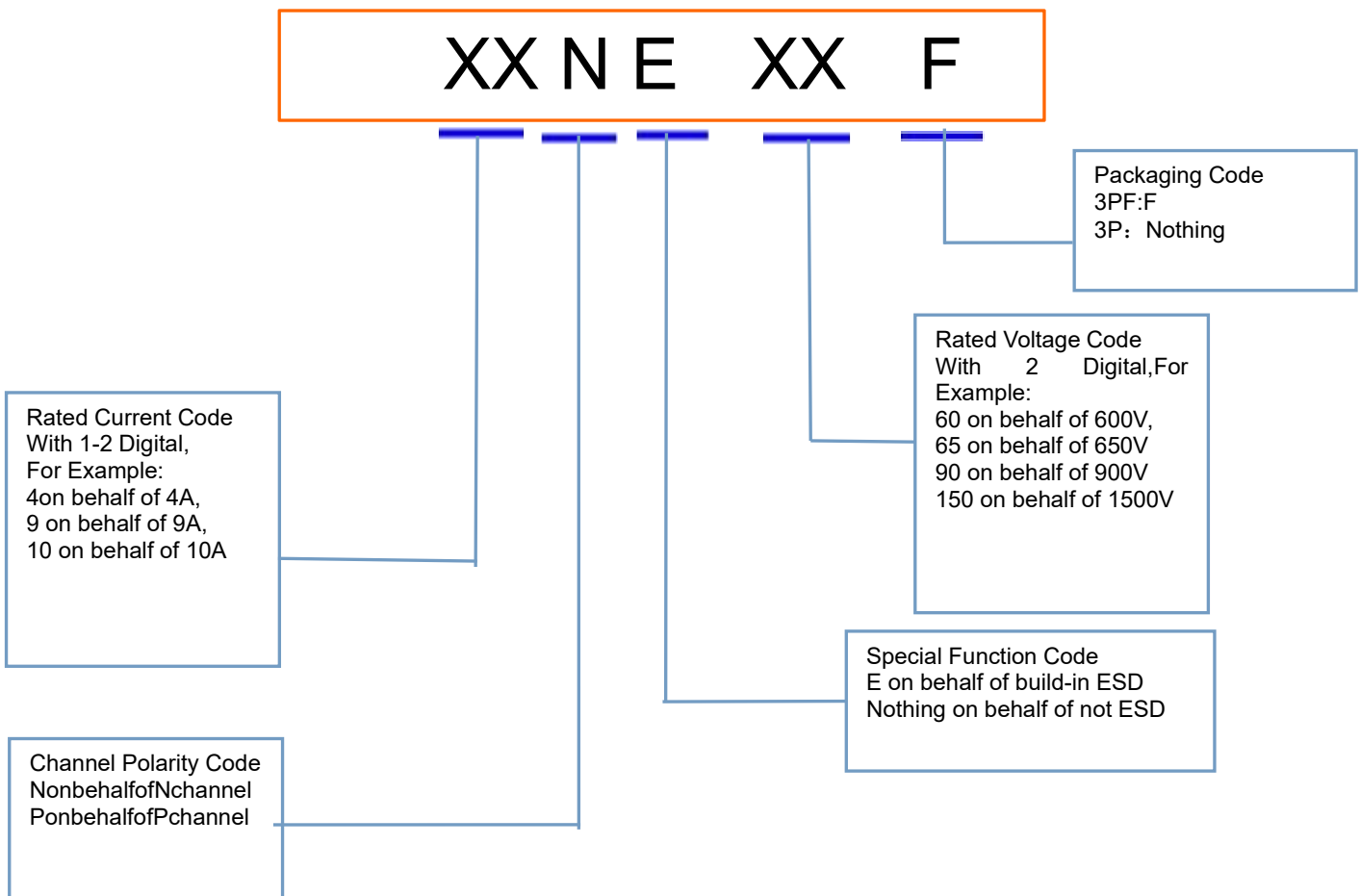

8 Product Specifications and Packaging Models

Product Model	Package Type	Mark Name	RoHS	Package	Quantity
DH4N150B	TO-247	4N150B	Pb-free	Tube	300/box

9 Dimensions

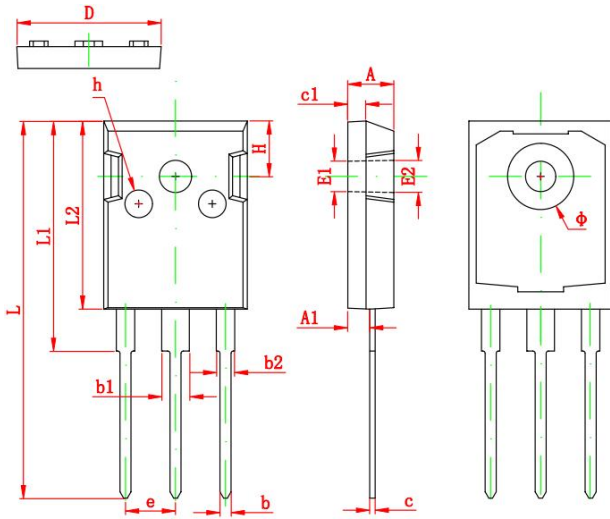

Symbol	Dimensions In Millimeters		Dimensions In Inches	
	Min	Max	Min	Max
A	4.850	5.150	0.191	0.200
A1	2.200	2.600	0.087	0.102
b	1.000	1.400	0.039	0.055
b1	2.800	3.200	0.110	0.126
b2	1.800	2.200	0.071	0.087
c	0.500	0.700	0.020	0.028
c1	1.900	2.100	0.075	0.083
D	15.450	15.750	0.608	0.620
E1	3.500 REF		0.138 REF	
E2	3.600 REF		0.142 REF	
L	40.900	41.300	1.610	1.626
L1	24.800	25.100	0.976	0.988
L2	20.300	20.600	0.799	0.811
Φ	7.100	7.300	0.280	0.287
e	5.450 TYP		0.215 TYP	
H	5.980 REF		0.235 REF	
h	0.000	0.300	0.000	0.012

10 Attentions

- Jiangsu Donghai Semiconductor Co.,Ltd. reserves the right to change the specification without prior notice! The customer should obtain the latest version of the information before making the order and verify that the information is complete and up to date.
- It is the responsibility of the purchaser for any failure or failure of any semiconductor product under certain conditions. It is the responsibility of the purchaser to comply with safety standards and to take safety measures in the system design and machine manufacturing of Jiangsu Donghai Semiconductor Co.,Ltd. products in order to avoid potential risk of failure. Injury or property damage.
- Product promotion is endless, our company will be dedicated to provide customers with better products.

11 Appendix

Revision history:

Date	REV.	Description	Page
2020.11.25	1.0	Original	