

## 120A 40V N-channel Enhancement Mode Power MOSFET

### 1 Description

These N-channel enhancement mode power mosfets used advanced trench technology design, provided excellent  $R_{DS(on)}$  and low gate charge. Which accords with the RoHS standard.

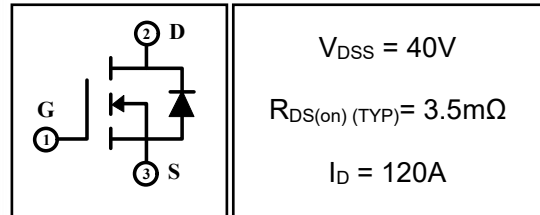

### 2 Features

- Low on resistance
- Low gate charge
- Fast switching
- Low reverse transfer capacitances
- 100% single pulse avalanche energy test
- 100%  $\Delta V_{DS}$  test

### 3 Applications

- Power switching applications
- Inverter management system
- Electric tools
- Automotive electronics

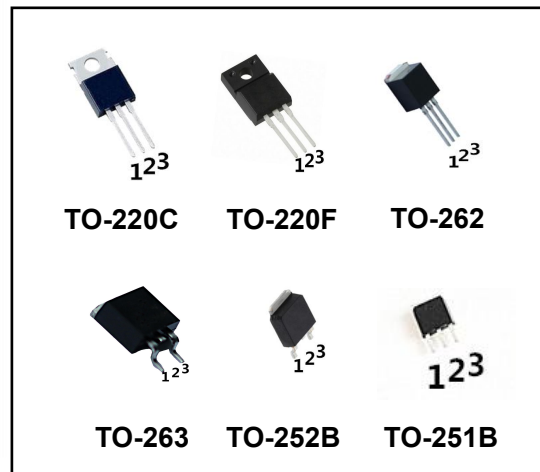

### 4 Electrical Characteristics

#### 4.1 Absolute Maximum Ratings (Tc=25°C, unless otherwise noted)

Parameter	Symbol	Rating		Units	
		DH033N04 DH033N04I/DH033N04E DH033N04B/DH033N04D	DH033N04F		
Drain-to-Source Voltage	$V_{DSS}$	40		V	
Gate-to-Source Voltage	$V_{GSS}$	±20		V	
Continuous Drain Current	$I_D$	$T_C=25^\circ C$	120	A	
		$T_C=100^\circ C$	85	A	
Pulsed Drain Current <sup>(1)</sup>	$I_{DM}$	360		A	
Single Pulse Avalanche Energy <sup>(4)</sup>	$E_{AS}$	449		mJ	
Avalanche Current <sup>(4)</sup>	$I_{AS}$	42		A	
Power Dissipation	$P_{tot}$	$T_a=25^\circ C$	2	2	W
		$T_C=25^\circ C$	133	30	W
Isolation Voltage	$V_{ISO}$	/	2500	V	
Junction Temperature Range	$T_j$	-55 ~ 175		°C	
Storage Temperature Range	$T_{stg}$	-55 ~ 175		°C	

#### 4.2 Thermal Characteristics

Parameter	Symbol	Rating		Units
		DH033N04 DH033N04I/DH033N04E DH033N04B/DH033N04D	DH033N04F	
Thermal Resistance, Junction to Case-sink	$R_{thJC}$	1.13	5	°C/W
Thermal Resistance, Junction to Ambient	$R_{thJA}$	75	75	°C/W

**4.3 Electrical Characteristics** (T<sub>c</sub>=25°C, unless otherwise noted)

Parameter	Symbol	Test Condition	Value			Units
			Min	Typ	Max	
<b>Off Characteristics</b>						
Drain-to-Source Breakdown Voltage	BV <sub>DSS</sub>	I <sub>D</sub> =250μA, V <sub>GS</sub> =0V	40	45	—	V
Drain-to-Source Leakage Current	I <sub>DSS</sub>	V <sub>DS</sub> =40V, V <sub>GS</sub> =0V, T <sub>C</sub> =25°C	—	—	1	μA
		V <sub>DS</sub> =40V, V <sub>GS</sub> =0V, T <sub>C</sub> =125°C	—	—	100	μA
Gate-to-Source Leakage Current	I <sub>GSS</sub>	V <sub>GS</sub> =±20V, V <sub>DS</sub> =0V	—	—	±100	nA
<b>On Characteristics</b>						
Gate Threshold Voltage	V <sub>GS(th)</sub>	V <sub>DS</sub> =V <sub>GS</sub> , I <sub>D</sub> =250μA	1	1.5	2	V
Drain-to-Source on-state Resistance	R <sub>DS(on)</sub>	V <sub>GS</sub> =10V, I <sub>D</sub> =30A	—	3.5	4.5	mΩ
	R <sub>DS(on)</sub>	V <sub>GS</sub> =4.5V, I <sub>D</sub> =30A	—	4.6	5.8	mΩ
<b>Dynamic Characteristics</b>						
Input Capacitance	C <sub>iss</sub>	V <sub>GS</sub> =0V, V <sub>DS</sub> =30V, f=1.0MHz	—	3676	—	pF
Output Capacitance	C <sub>oss</sub>		—	406	—	
Reverse Transfer Capacitance	C <sub>rss</sub>		—	333	—	
Gate Resisitance	R <sub>G</sub>	V <sub>DD</sub> =0V, V <sub>GS</sub> =0V, F=1MHz	—	2.8	—	Ω
<b>Switching Characteristics</b>						
Turn-on Delay Time	t <sub>d(on)</sub>	I <sub>D</sub> =60A, V <sub>DD</sub> =15V, V <sub>GS</sub> =4.5V, R <sub>GEN</sub> =2Ω	—	19.6	—	nS
Turn-on Rise Time	t <sub>r</sub>		—	117	—	
Turn-off Delay Time	t <sub>d(off)</sub>		—	59	—	
Turn-off Fall Time	t <sub>f</sub>		—	116	—	
Total Gate Charge	Q <sub>g</sub>	I <sub>D</sub> =60A, V <sub>DD</sub> =15V, V <sub>GS</sub> =10V	—	87	—	nC
Gate-to-Source Charge	Q <sub>gs</sub>		—	14	—	
Gate-to-Drain("Miller") Charge	Q <sub>gd</sub>		—	22	—	
<b>Drain-Source Diode Characteristics</b>						
Diode Forward Voltage <sup>(3)</sup>	V <sub>SD</sub>	V <sub>GS</sub> =0V, I <sub>S</sub> =50A	—	0.88	1.2	V
Diode Forward Current	I <sub>S</sub>		—	—	120	A
Reverse Recovery Time <sup>(3)</sup>	t <sub>rr</sub>	T <sub>J</sub> =25°C, I <sub>F</sub> =40A, di <sub>F</sub> /dt=100A/μS, V <sub>GS</sub> =0V	—	30	—	nS
Reverse Recovery Charge <sup>(3)</sup>	Q <sub>rr</sub>		—	15	—	nC

Notes:

- 1: Repetitive rating, pulse width limited by maximum junction temperature.
- 2: Surface mounted on FR4 Board, t<sub>s</sub>≤10sec.
- 3: Pulse width ≤ 300μs, duty cycle ≤ 2%.
- 4: L=0.5mH, I<sub>D</sub>=42A, V<sub>DD</sub>=32V, V<sub>GATE</sub>=40V, Start T<sub>J</sub>=25°C.

## 5 Typical characteristics diagrams

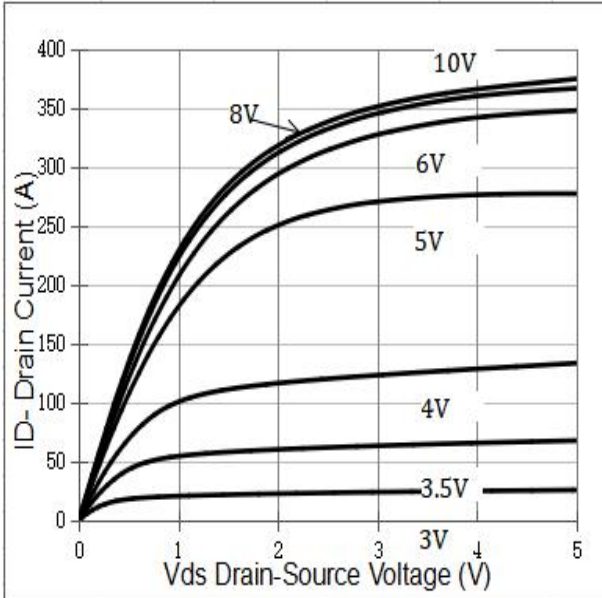

Figure 1 Output Characteristics

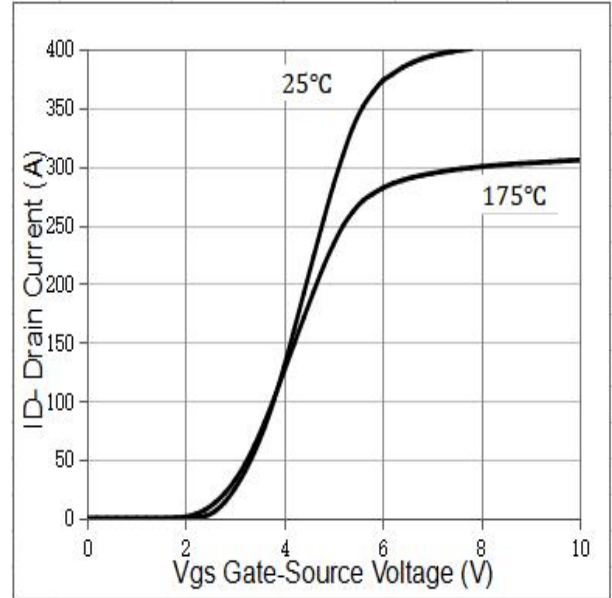

Figure 2 Transfer Characteristics

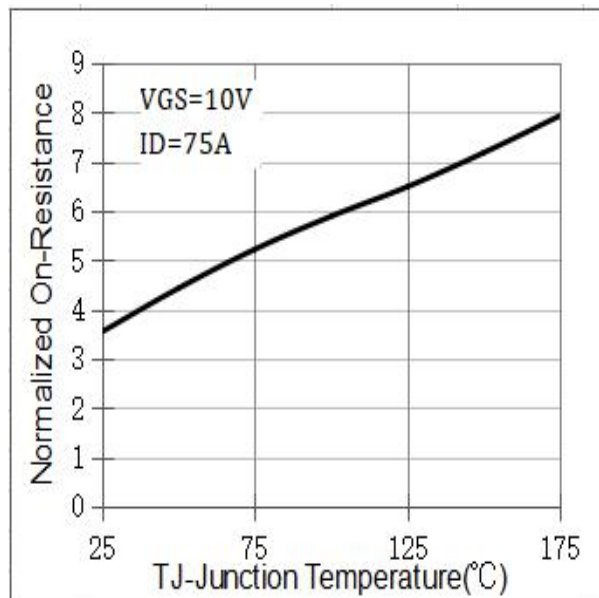

Fig3. Rdson-Junction Temperature

5 Typical characteristics diagrams(continues)

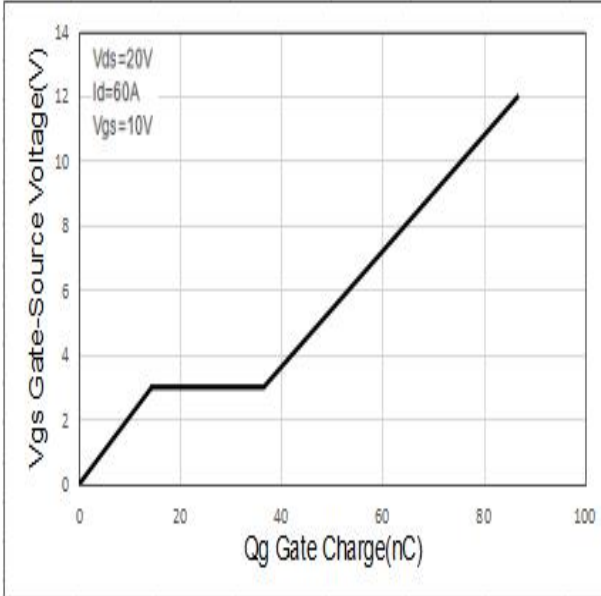

Fig 4. Gate Charge

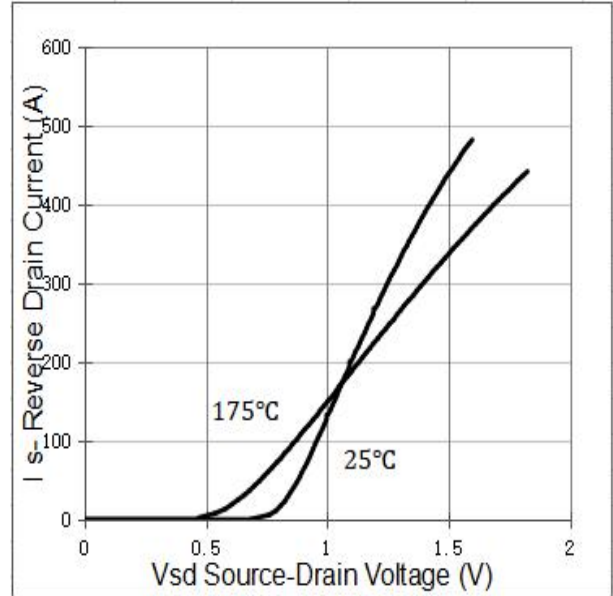

Fig 5. Source-Drain Diode Forward

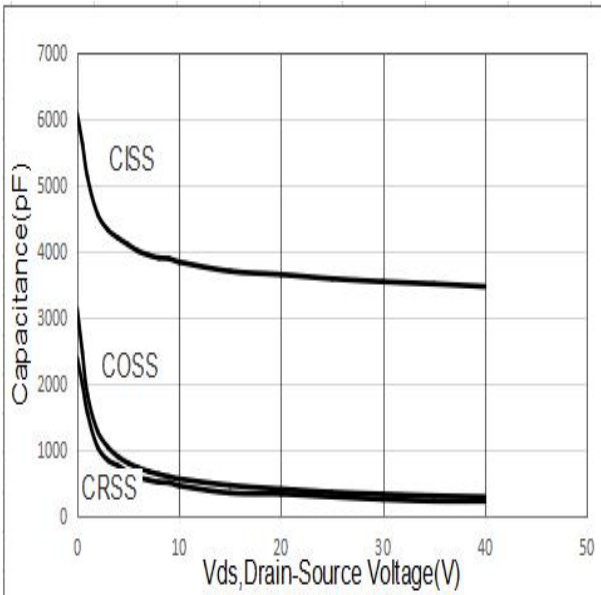

Figure 6. Capacitance Characteristics

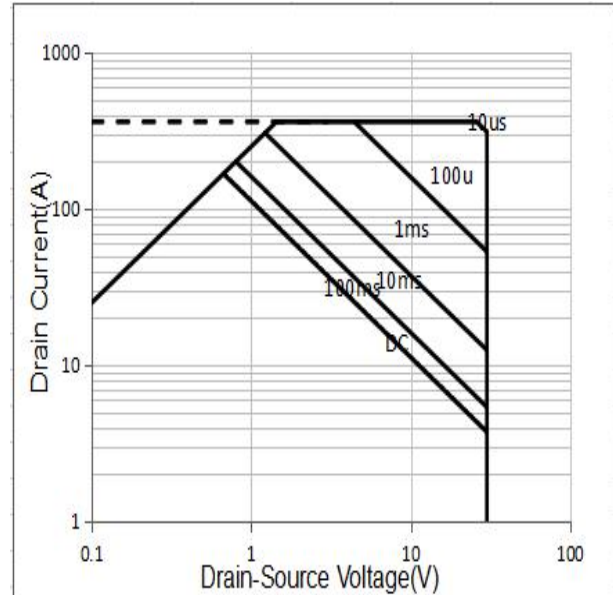

Figure 7. Safe Operating Area

5 Typical characteristics diagrams(continues)

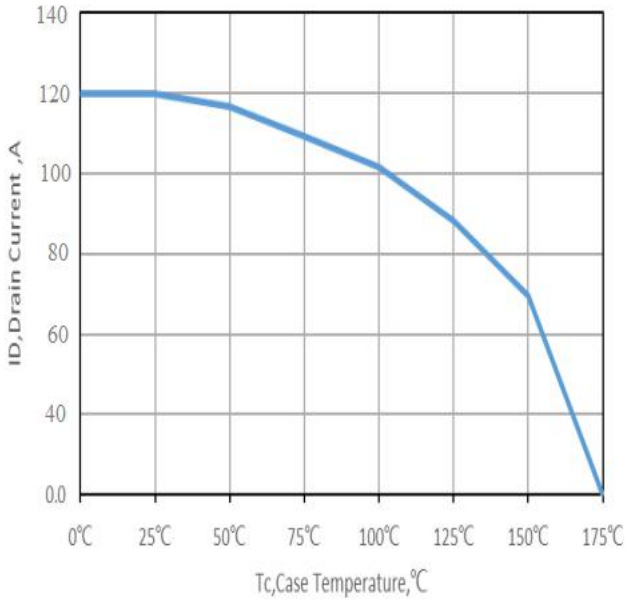

Figure 8. ID Current De-rating

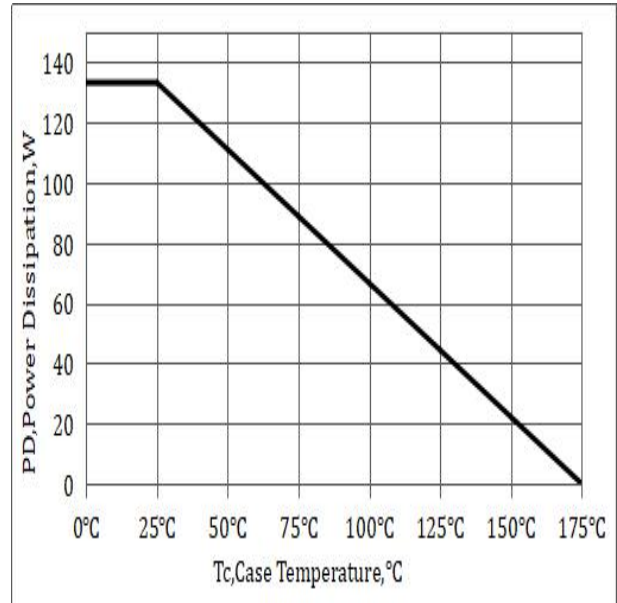

Figure 9. Power De-rating

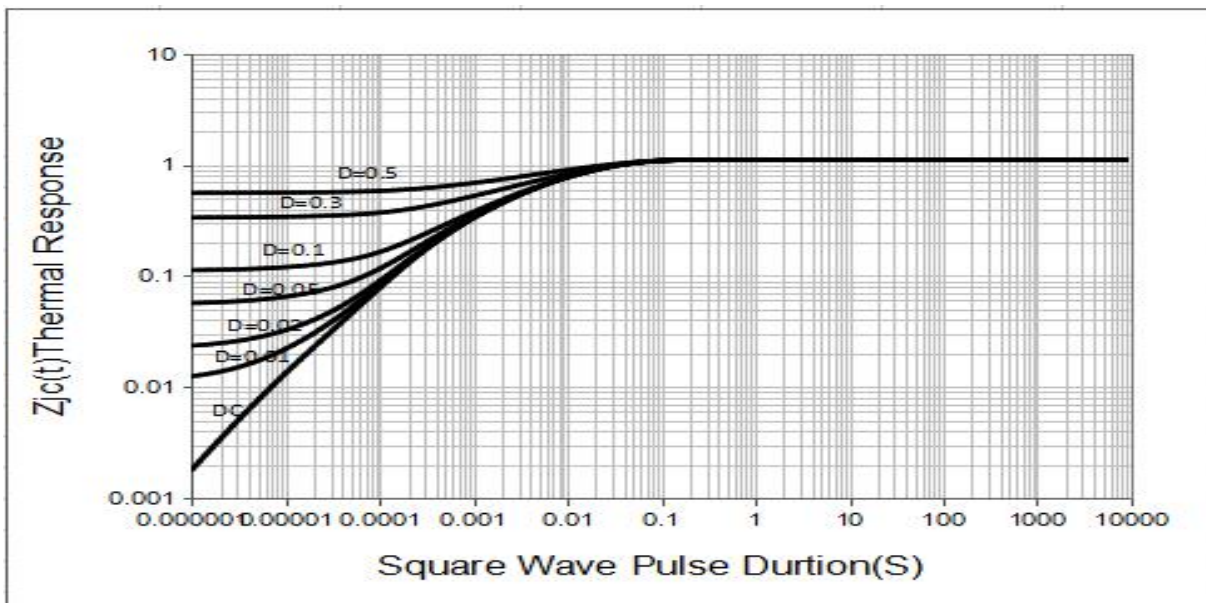
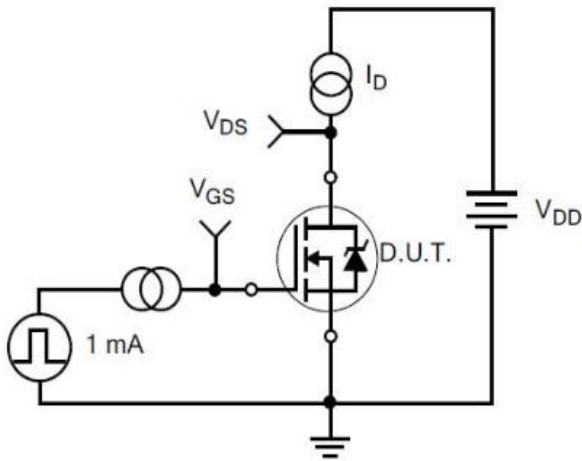
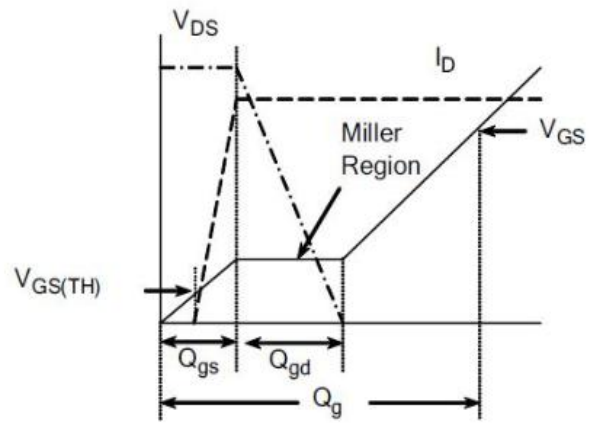

Fig 10. Normalized Maximum Transient Thermal Impedance

## 6 Typical Test Circuit and Waveform



1) Gate Charge Test Circuit



2) . Gate Charge Waveform

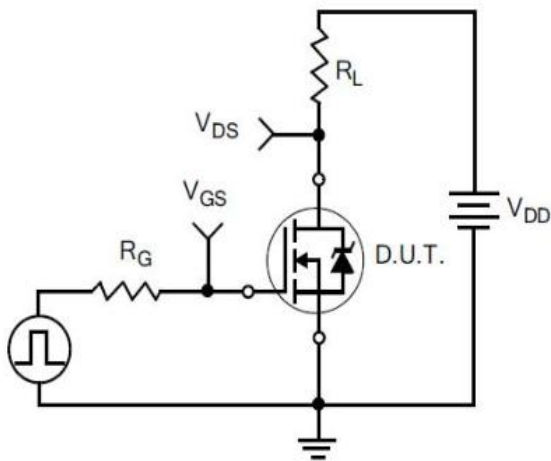

3) Resistive Switching Test Circuit

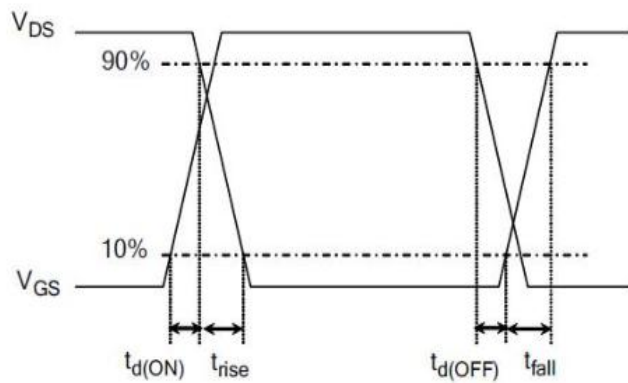

4) Resistive Switching Waveforms

6 Typical Test Circuit and Waveform(continues)

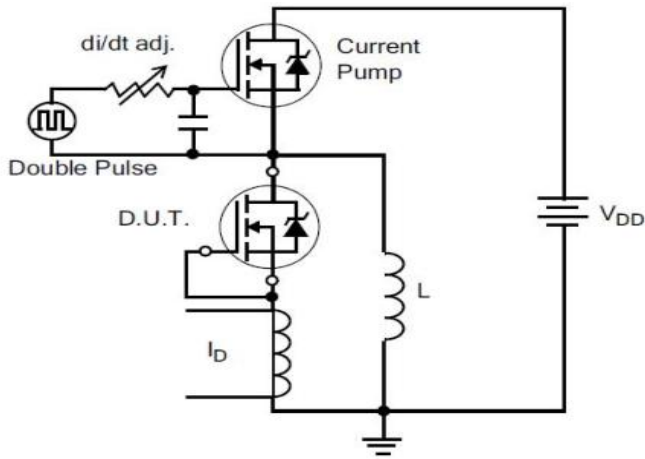

5) Diode Reverse Recovery Test Circuit

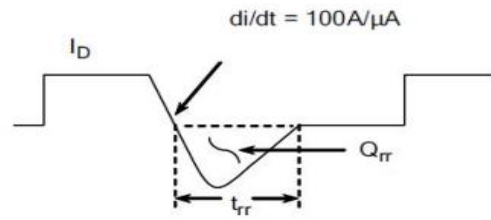

6) Diode Reverse Recovery Waveform

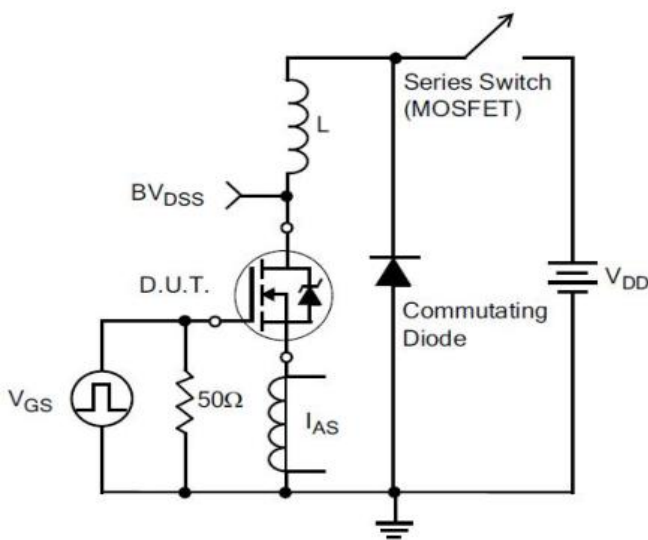

7) . Unclamped Inductive Switching Test Circuit

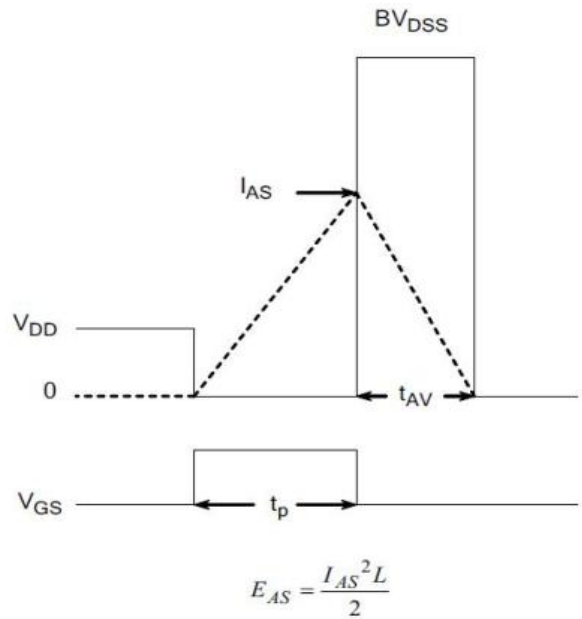

8) Unclamped Inductive Switching Waveforms

## 7 Product Names Rules

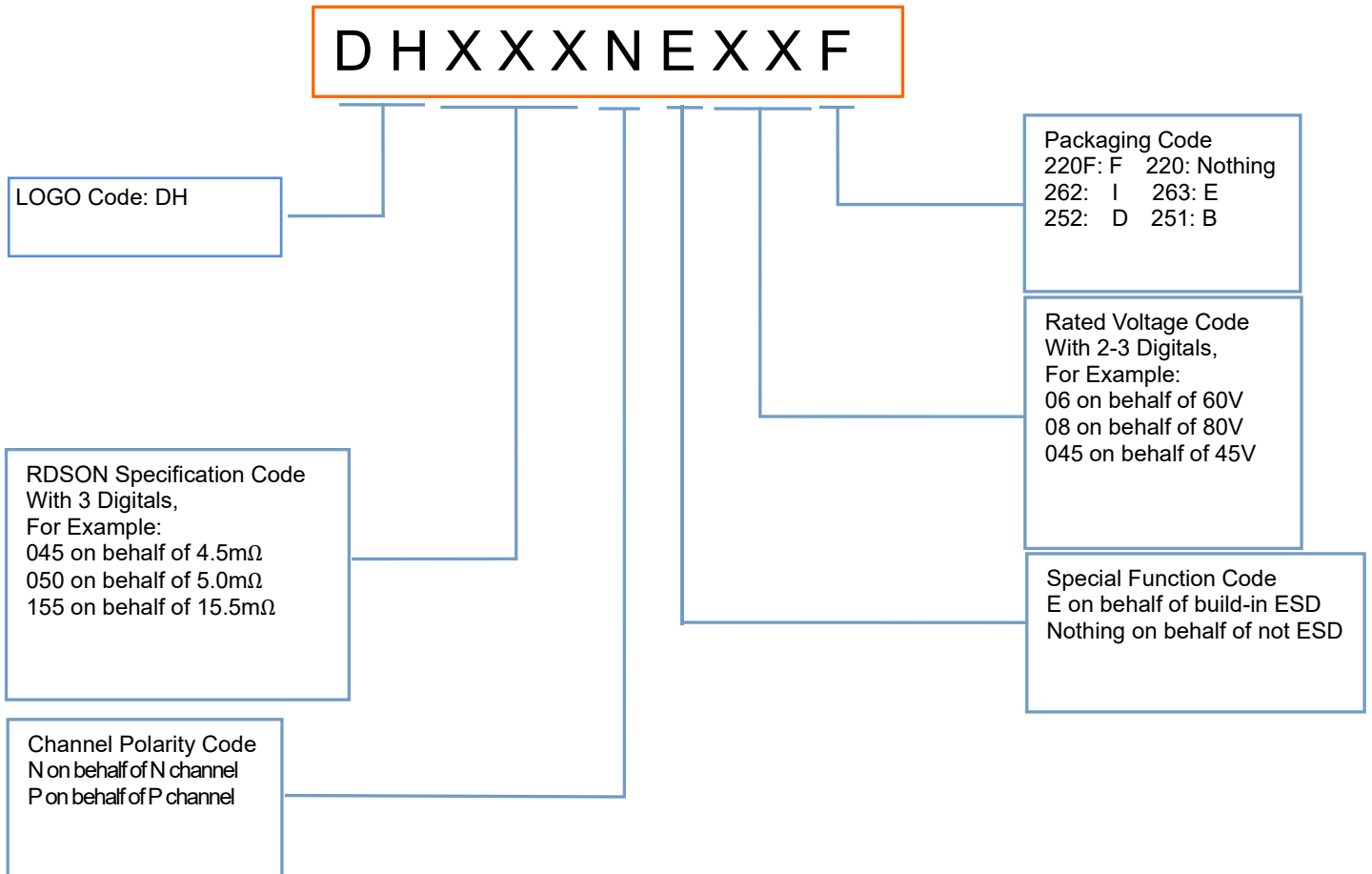

## 8 Product Specifications and Packaging Models

Product Model	Package Type	Mark Name	RoHS	Package	Quantity
DH033N04	TO-220	DH033N04	Pb-free	Tube	1000/box
DH033N04F	TO-220F	DH033N04F	Pb-free	Tube	1000/box
DH033N04B	TO-251	DH033N04B	Pb-free	Tube	3000/box
DH033N04D	TO-252	DH033N04D	Pb-free	Tape & Reel	2500/box
DH033N04I	TO-262	DH033N04I	Pb-free	Tube	1000/box
DH033N04E	TO-263	DH033N04E	Pb-free	Tape & Reel	800/box



## 9 Dimensions

TO-251B PACKAGE OUTLINE DIMENSIONS

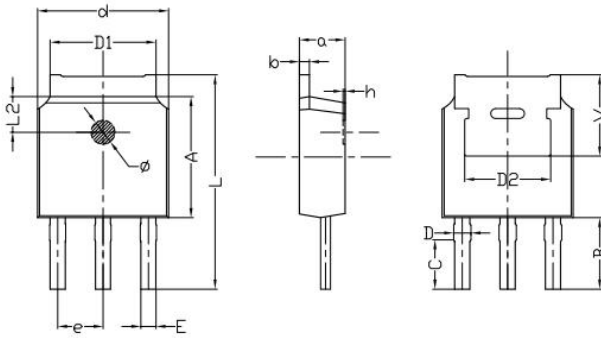

Symbol	Dimensions In Millimeters		Dimensions In Inches	
	min.	max.	min.	max.
a	2.20	2.40	0.087	0.0946
b	0.46	0.58	0.018	0.023
C	2.45	2.65	0.097	0.104
D	0.80	0.90	0.032	0.035
d	6.30	6.70	0.248	0.264
D1	5.00	5.50	0.197	0.217
D2	TYP 4.83		TYP 0.190	
A	5.80	6.20	0.228	0.244
e	2.19	2.39	0.086	0.094
L	10.40	11.00	0.4098	0.4334
B	3.50	3.70	0.1379	0.1458
L2	1.5	1.8	0.059	0.071
Φ	1.10	1.30	0.0433	0.0512
h	0.00	0.30	0.000	0.012
V	5.25	5.85	0.207	0.230
E	0.60	0.80	0.0236	0.0315

TO-252B PACKAGE OUTLINE DIMENSIONS

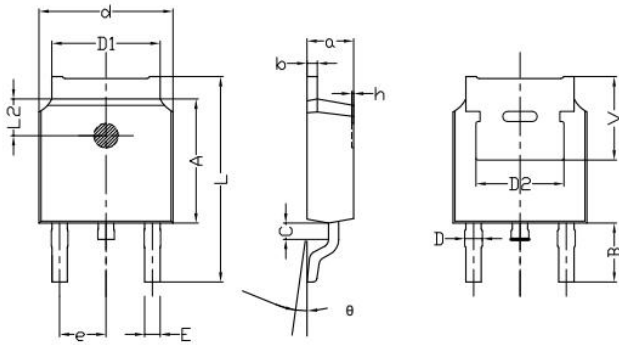

Symbol	Dimensions In Millimeters		Dimensions In Inches	
	min.	max.	min.	max.
a	2.20	2.40	0.087	0.095
b	0.46	0.58	0.018	0.023
c	0.70	0.90	0.028	0.035
D	0.80	1.00	0.032	0.039
d	6.30	6.70	0.248	0.264
D1	5.00	5.50	0.197	0.217
D2	TYP 4.83		TYP 0.190	
A	5.80	6.20	0.228	0.244
e	2.19	2.39	0.086	0.094
L	9.40	10.40	0.370	0.409
B	2.6	3.2	0.102	0.126
L2	1.5	1.8	0.059	0.071
θ	0	8	0	8
h	0	0.3	0	0.012
V	5.25	5.85	0.207	0.230
E	0.6	0.8	0.024	0.032

**9 Dimensions(continues)**

TO-220C PACKAGE OUTLINE DIMENSIONS

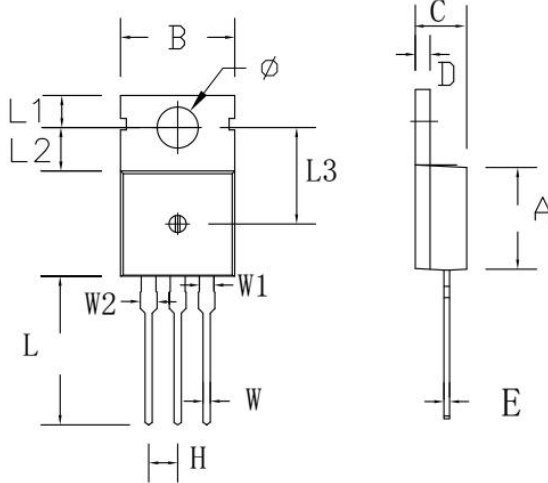

Symbol	Dimensions In Millimeters		Dimensions In Inches	
	min.	max.	min.	max.
A	8.80	9.30	0.346	0.366
B	9.70	10.30	0.382	0.406
C	4.25	4.75	0.167	0.187
D	1.20	1.45	0.047	0.057
E	0.40	0.60	0.016	0.024
H	2.54 TYP		0.100 TYP	
W	0.60	0.95	0.024	0.037
W1	1.05	1.45	0.041	0.057
W2	1.20	1.60	0.047	0.063
L	12.60	13.40	0.496	0.528
L1	2.45	2.95	0.096	0.116
L2	3.45	3.95	0.136	0.156
L3	8.15	8.65	0.321	0.341
Φ	3.50	3.90	0.138	0.154

TO-220F PACKAGE OUTLINE DIMENSIONS

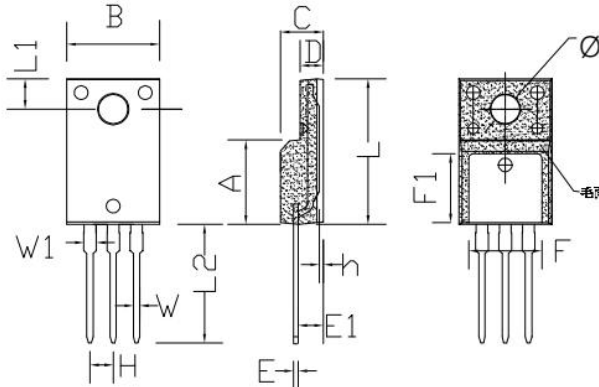

Symbol	Dimensions In Millimeters		Dimensions In Inches	
	min.	max.	min.	max.
A	8.80	9.30	0.346	0.366
B	10.00	10.50	0.394	0.413
C	4.30	4.90	0.169	0.193
D	2.30	2.70	0.091	0.106
L	15.55	16.15	0.612	0.636
h	0.40	0.60	0.016	0.024
L1	3.15	3.55	0.124	0.140
L2	12.65	13.35	0.498	0.526
W	0.70	0.90	0.028	0.035
W1	1.15	1.55	0.045	0.061
H	2.54 TYP		0.100 TYP	
E	0.48	0.53	0.019	0.021
Φ	2.90	3.40	0.114	0.134
E1	2.40	2.90	0.094	0.114
F	7.75	8.25	0.305	0.325
F1	7.35	7.85	0.289	0.309

**9 Dimensions(continues)**

TO-262 PACKAGE OUTLINE DIMENSIONS

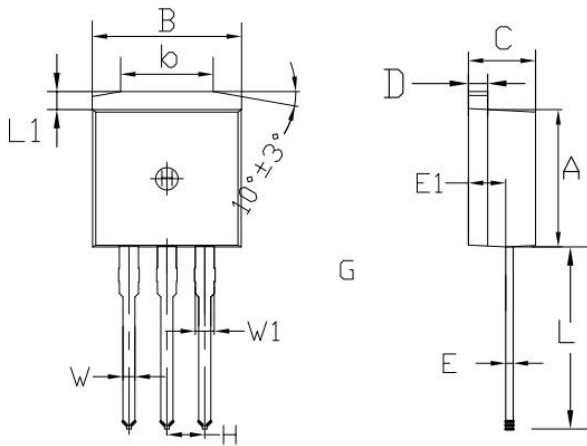

Symbol	Dimensions In Millimeters		Dimensions In Inches	
	min.	max.	min.	max.
A	8.80	9.30	0.346	0.366
B	9.70	10.30	0.382	0.406
C	4.25	4.75	0.167	0.187
D	1.20	1.45	0.047	0.057
E	0.40	0.60	0.016	0.024
L	12.25	13.75	0.482	0.541
L1	1.15	1.45	0.045	0.057
E1	2.4	2.6	0.0945	0.1024
W	0.80	0.82	0.0315	0.034
W1	1.20	1.30	0.047	0.051
H	2.54 TYP		0.200 TYP	
b	5.50	6.50	0.216	0.256

TO-263 PACKAGE OUTLINE DIMENSIONS

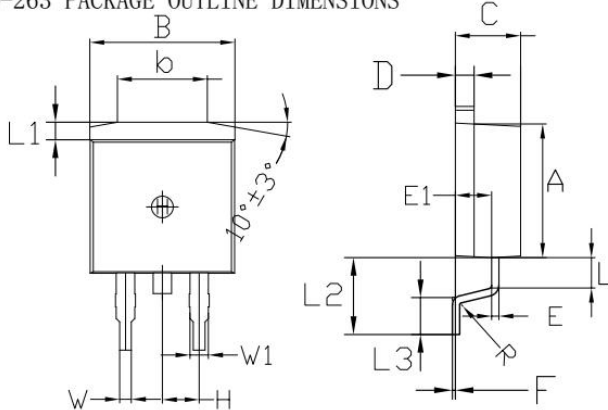

Symbol	Dimensions In Millimeters		Dimensions In Inches	
	min.	max.	min.	max.
A	8.80	9.30	0.346	0.366
B	9.70	10.30	0.382	0.406
C	4.25	4.75	0.167	0.187
D	1.20	1.45	0.047	0.057
E	0.40	0.60	0.016	0.024
L	1.90	2.30	0.075	0.091
L1	1.15	1.45	0.045	0.057
R	0.24	0.26	0.0095	0.0102
W	0.80	0.82	0.0315	0.0323
W1	1.20	1.30	0.047	0.051
H	2.54 TYP		0.200 TYP	
b	5.50	6.50	0.216	0.256
E1	2.4	2.6	0.0946	0.1024
L2	5.20	5.80	0.205	0.228
L3	2.20	3.20	0.087	0.126
F	0.03	0.23	0.0012	0.0091

## 10 Attentions

- Jiangsu Donghai Semiconductor Technology CO.,LTD. reserves the right to change the specification without prior notice! The customer should obtain the latest version of the information before making the order and verify that the information is complete and up to date.
- It is the responsibility of the purchaser for any failure or failure of any semiconductor product under certain conditions. It is the responsibility of the purchaser to comply with safety standards and to take safety measures in the system design and machine manufacturing of Donghai products in order to avoid potential risk of failure. Injury or property damage.
- Product promotion is endless, our company will be dedicated to provide customers with better products.

## 11 Appendix

Revision history:

Date	REV.	Description	Page
2020.07.02	1.0	Original	