

## 120A 98V N-channel Enhancement Mode Power MOSFET

### 1 Description

These N-channel enhancement mode power mosfets used advanced splite gate trench technology design, provided excellent  $R_{DS(on)}$  and low gate charge. Which accords with the RoHS standard.

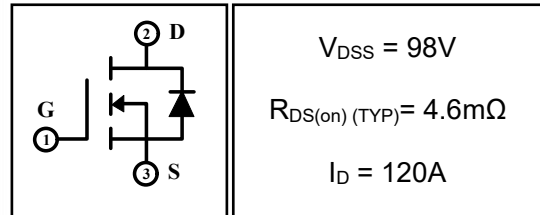

### 2 Features

- Fast switching
- Low on resistance
- Low gate charge
- High avalanche current
- Low reverse transfer capacitances
- 100% single pulse avalanche energy test
- 100%  $\Delta V_{DS}$  test

### 3 Applications

- Synchronous rectification in SMPS
- Hard switching and high speed circuit
- Power tools
- UPS
- Motor control

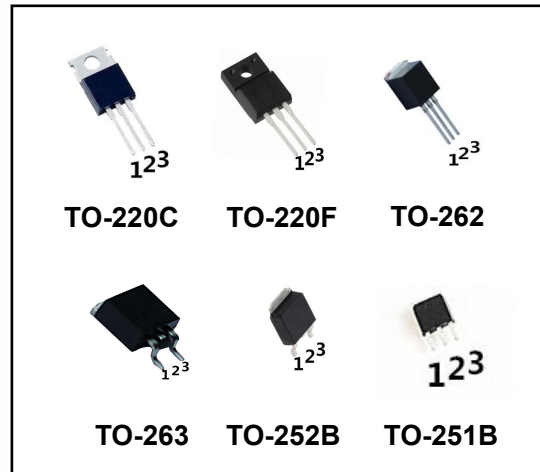

### 4 Electrical Characteristics

#### 4.1 Absolute Maximum Ratings (Tc=25°C, unless otherwise noted)

Parameter	Symbol	Rating				Units
		DHS046 N10	DHS046N10I DHS046N10E	DHS046N10B DHS046N10D	DHS046N10F	
Drain-to-Source Voltage	$V_{DSS}$	98				V
Gate-to-Source Voltage	$V_{GSS}$	±20				V
Continuous Drain Current	$T_C=25^\circ C$	120				A
	$T_C=100^\circ C$	90				A
Pulsed Drain Current <sup>(1)</sup>	$I_{DM}$	480				A
Single Pulse Avalanche Energy <sup>(4)</sup>	$E_{AS}$	400				mJ
Avalanche Current <sup>(4)</sup>	$I_{AS}$	40				A
Power Dissipation	$T_a=25^\circ C$	2	2	2	2	W
	$T_C=25^\circ C$	160	160	160	34	W
Isolation Voltage	$V_{ISO}$	/			2500	V
Junction Temperature Range	$T_j$	-55~150				°C
Storage Temperature Range	$T_{stg}$	-55~150				°C

#### 4.2 Thermal Characteristics

Parameter	Symbol	Rating				Units
		DHS046 N10	DHS046N10I DHS046N10E	DHS046N10B DHS046N10D	DHS046N10F	
Thermal Resistance, Junction to Case-sink	$R_{thJC}$	0.78	0.78	0.78	3.68	°C/W
Thermal Resistance, Junction to Ambient	$R_{thJA}$	62.5	62.5	62.5	62.5	°C/W

**4.3 Electrical Characteristics** (Tc=25°C, unless otherwise noted)

Parameter	Symbol	Test Condition	Value			Units
			Min	Typ	Max	
<b>Off Characteristics</b>						
Drain-to-Source Breakdown Voltage	BV <sub>DSS</sub>	I <sub>D</sub> =250μA, V <sub>GS</sub> =0V	98	--	--	V
Drain-to-Source Leakage Current	I <sub>DSS</sub>	V <sub>DS</sub> =98V, V <sub>GS</sub> =0V, T <sub>C</sub> =25°C	--	--	1	μA
		V <sub>DS</sub> =80V, V <sub>GS</sub> =0V, T <sub>C</sub> =125°C	--	--	100	μA
Gate-to-Source Leakage Current	I <sub>GSS</sub>	V <sub>GS</sub> =±20V, V <sub>DS</sub> =0V	--	--	±100	nA
<b>On Characteristics</b>						
Gate Threshold Voltage	V <sub>GS(th)</sub>	V <sub>DS</sub> =V <sub>GS</sub> , I <sub>D</sub> =250μA	2	3	4	V
Drain-to-Source on-state Resistance	R <sub>DS(on)</sub>	V <sub>GS</sub> =10V, I <sub>D</sub> =50A	--	4.6	5.5	mΩ
<b>Dynamic Characteristics</b>						
Input Capacitance	C <sub>iss</sub>	V <sub>GS</sub> =0V, V <sub>DS</sub> =40V, f=1.0MHz	--	3815	--	pF
Output Capacitance	C <sub>oss</sub>		--	652	--	
Reverse Transfer Capacitance	C <sub>rss</sub>		--	26	--	
Gate Resisitance	R <sub>G</sub>	V <sub>DD</sub> =0V, V <sub>GS</sub> =0V, F=1MHz	--	3.0	--	Ω
<b>Switching Characteristics</b>						
Turn-on Delay Time	t <sub>d(on)</sub>	I <sub>D</sub> =13.3A, V <sub>DD</sub> =40V, V <sub>GS</sub> =10V, R <sub>GEN</sub> =24Ω	--	49	--	nS
Turn-on Rise Time	t <sub>r</sub>		--	76	--	
Turn-off Delay Time	t <sub>d(off)</sub>		--	157	--	
Turn-off Fall Time	t <sub>f</sub>		--	87	--	
Total Gate Charge	Q <sub>g</sub>	I <sub>D</sub> =50A, V <sub>DD</sub> =40V, V <sub>GS</sub> =10V	--	64	--	nC
Gate-to-Source Charge	Q <sub>gs</sub>		--	23	--	
Gate-to-Drain("Miller") Charge	Q <sub>gd</sub>		--	17	--	
<b>Drain-Source Diode Characteristics</b>						
Diode Forward Voltage <sup>(3)</sup>	V <sub>SD</sub>	V <sub>GS</sub> =0V, I <sub>S</sub> =50A	--	--	1.4	V
Diode Forward Current	I <sub>S</sub>		--	--	120	A
Reverse Recovery Time <sup>(3)</sup>	t <sub>rr</sub>	T <sub>J</sub> =25°C, I <sub>F</sub> =20A, di <sub>F</sub> /dt=100A/μS, V <sub>GS</sub> =0V	--	66	--	nS
Reverse Recovery Charge <sup>(3)</sup>	Q <sub>rr</sub>		--	150	--	nC

Notes:

- 1: Repetitive rating, pulse width limited by maximum junction temperature.
- 2: Surface mounted on FR4 Board, t≤10sec.
- 3: Pulse width ≤ 300μs, duty cycle ≤ 2%.
- 4: L=0.5mH, I<sub>D</sub>=40A, V<sub>DD</sub>=80V, R<sub>G</sub>=25Ω, V<sub>GATE</sub>=100V, Start T<sub>J</sub>=25°C.

## 5 Typical characteristics diagrams

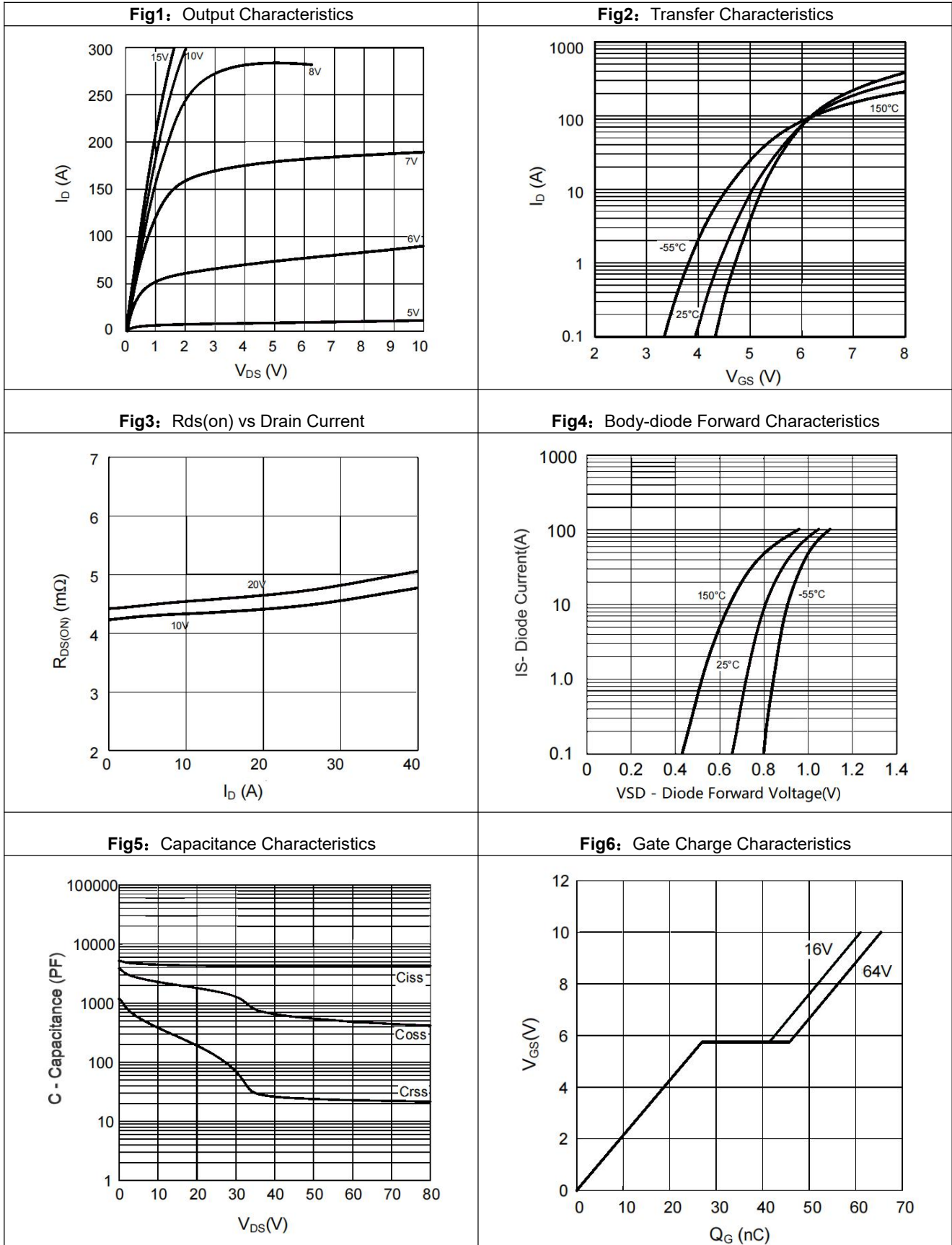

## 6 Typical characteristics diagrams(Continues)

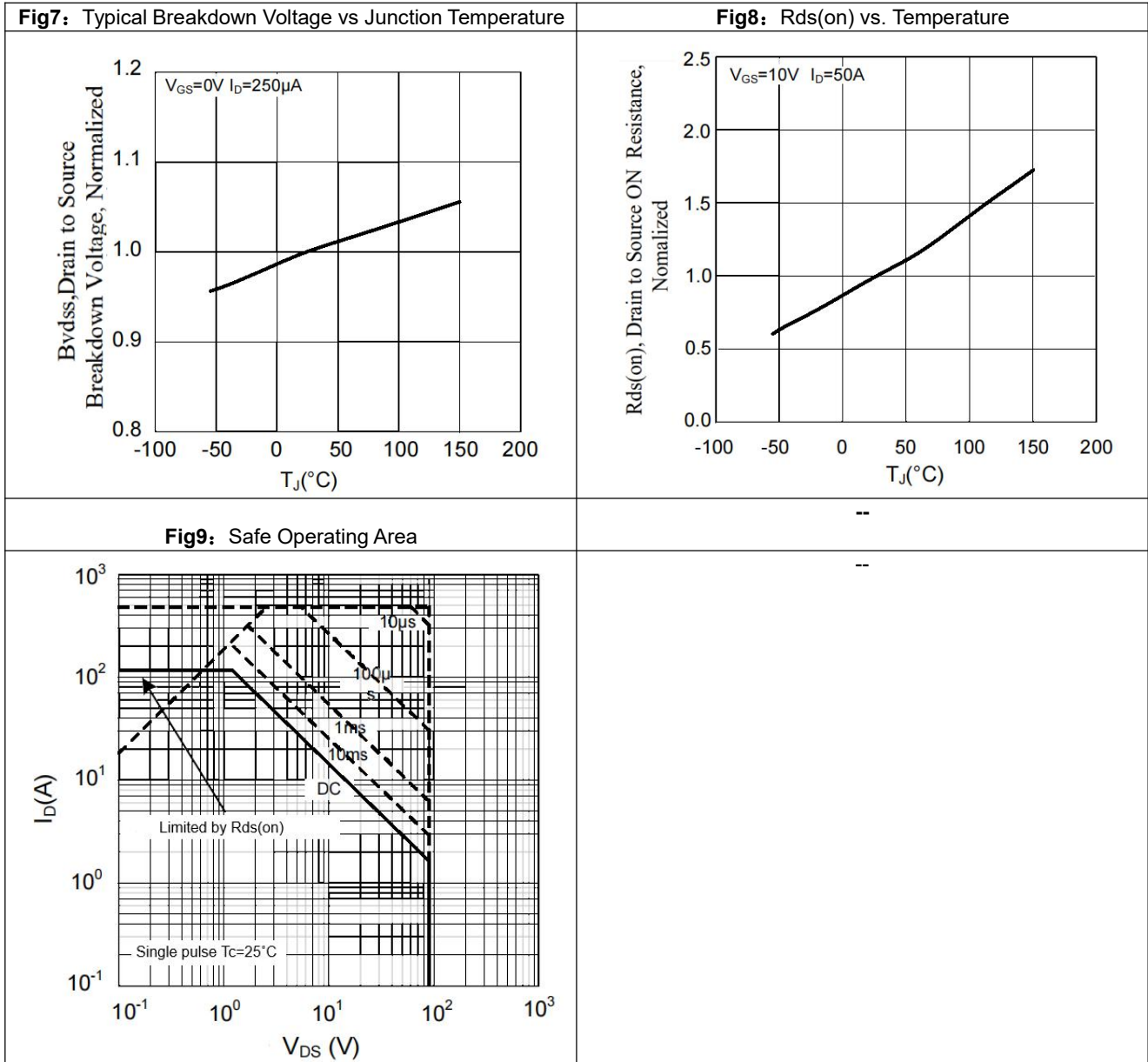

## 6 Typical Test Circuit and Waveform

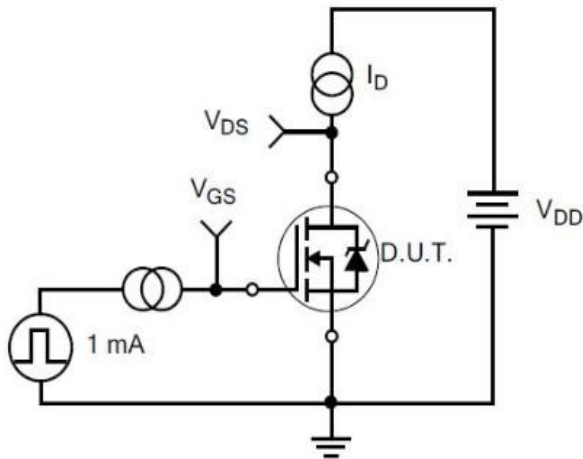

1) Gate Charge Test Circuit

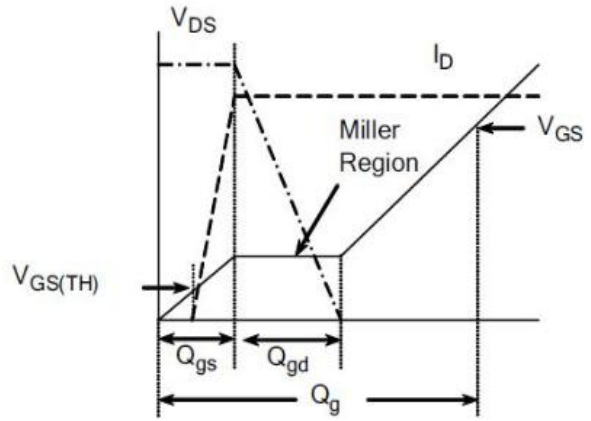

2) . Gate Charge Waveform

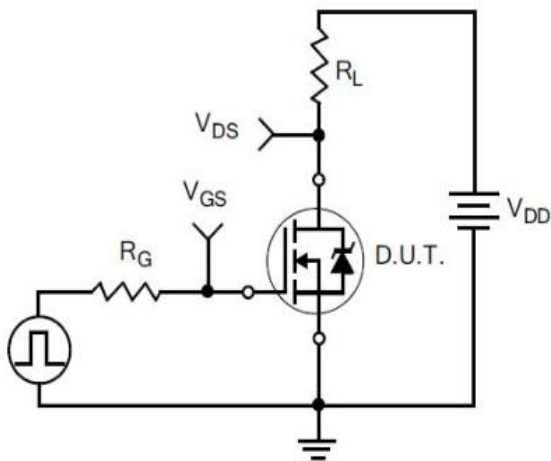

3) Resistive Switching Test Circuit

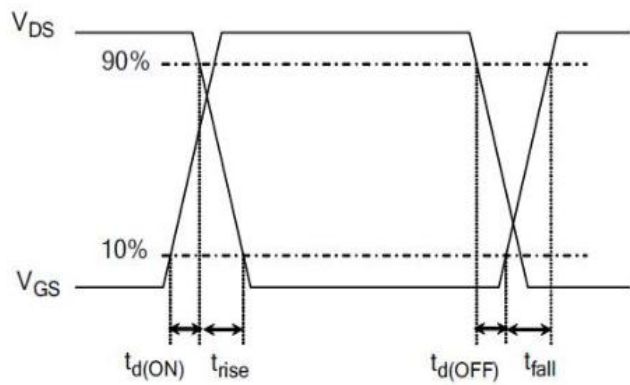

4) Resistive Switching Waveforms

6 Typical Test Circuit and Waveform(continues)

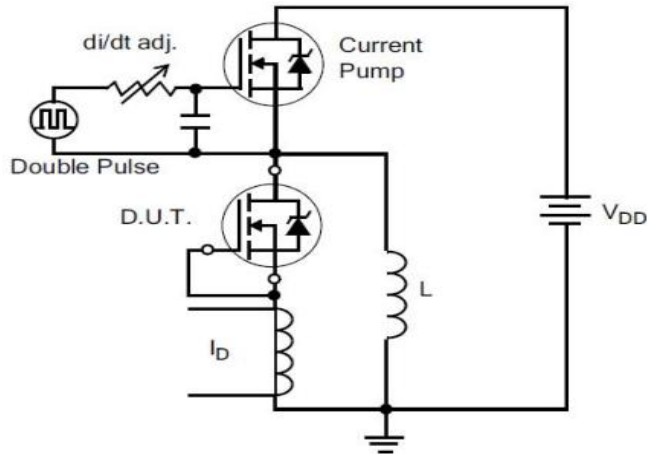

5) Diode Reverse Recovery Test Circuit

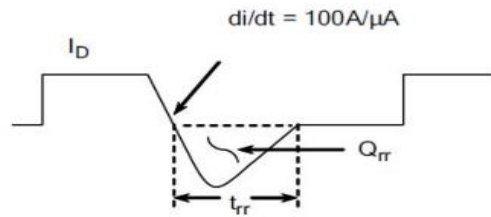

6) Diode Reverse Recovery Waveform

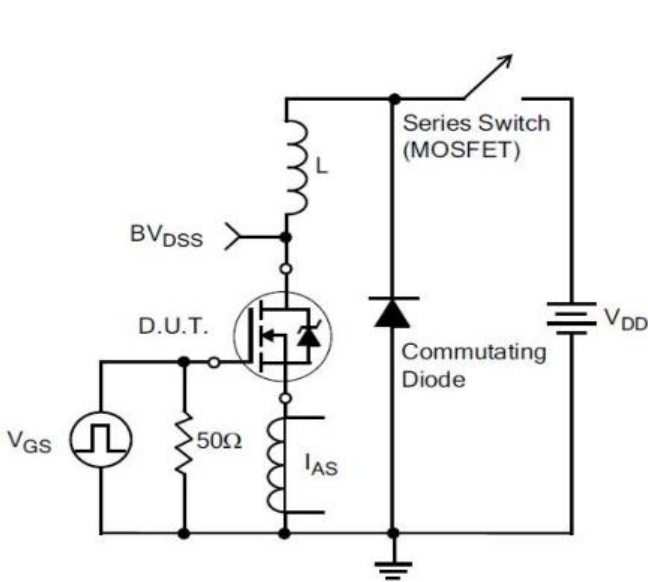

7) . Unclamped Inductive Switching Test Circuit

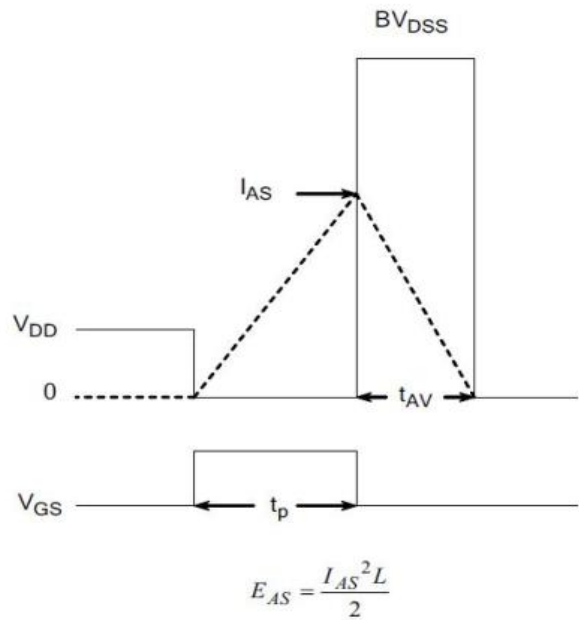

8) Unclamped Inductive Switching Waveforms

## 7 Product Names Rules

D H S X X X N E X X F

LOGO Code: DH

Process Code:  
Spilt Gate Trench: S

RDSON Specification Code  
With 3 Digitals,  
For Example:  
045 on behalf of 4.5mΩ  
050 on behalf of 5.0mΩ  
155 on behalf of 15.5mΩ

Channel Polarity Code  
N on behalf of N channel  
P on behalf of P channel

Packaging Code  
220F: F 220: Nothing  
262: I 263: E  
252: D 251: B

Rated Voltage Code  
With 2-3 Digitals,  
For Example:  
06 on behalf of 60V  
08 on behalf of 80V  
045 on behalf of 45V

Special Function Code  
E on behalf of build-in ESD  
Nothing on behalf of not ESD

## 8 Product Specifications and Packaging Models

Product Model	Package Type	Mark Name	RoHS	Package	Quantity
DHS046N10	TO-220	DHS046N10	Pb-free	Tube	1000/box
DHS046N10F	TO-220F	DHS046N10F	Pb-free	Tube	1000/box
DHS046N10B	TO-251	DHS046N10B	Pb-free	Tube	3000/box
DHS046N10D	TO-252	DHS046N10D	Pb-free	Tape & Reel	2500/box
DHS046N10I	TO-262	DHS046N10I	Pb-free	Tube	1000/box
DHS046N10E	TO-263	DHS046N10E	Pb-free	Tape & Reel	800/box



## 9 Dimensions

TO-251B PACKAGE OUTLINE DIMENSIONS

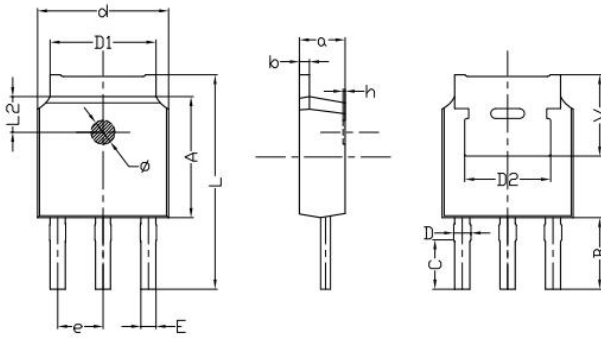

Symbol	Dimensions In Millimeters		Dimensions In Inches	
	min.	max.	min.	max.
a	2.20	2.40	0.087	0.0946
b	0.46	0.58	0.018	0.023
C	2.45	2.65	0.097	0.104
D	0.80	0.90	0.032	0.035
d	6.30	6.70	0.248	0.264
D1	5.00	5.50	0.197	0.217
D2	TYP 4.83		TYP 0.190	
A	5.80	6.20	0.228	0.244
e	2.19	2.39	0.086	0.094
L	10.40	11.00	0.4098	0.4334
B	3.50	3.70	0.1379	0.1458
L2	1.5	1.8	0.059	0.071
Φ	1.10	1.30	0.0433	0.0512
h	0.00	0.30	0.000	0.012
V	5.25	5.85	0.207	0.230
E	0.60	0.80	0.0236	0.0315

TO-252B PACKAGE OUTLINE DIMENSIONS

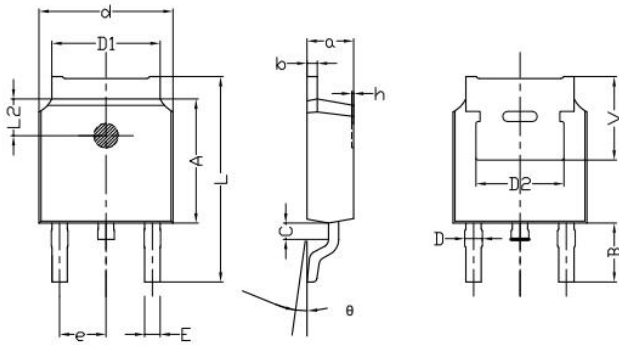

Symbol	Dimensions In Millimeters		Dimensions In Inches	
	min.	max.	min.	max.
a	2.20	2.40	0.087	0.095
b	0.46	0.58	0.018	0.023
c	0.70	0.90	0.028	0.035
D	0.80	1.00	0.032	0.039
d	6.30	6.70	0.248	0.264
D1	5.00	5.50	0.197	0.217
D2	TYP 4.83		TYP 0.190	
A	5.80	6.20	0.228	0.244
e	2.19	2.39	0.086	0.094
L	9.40	10.40	0.370	0.409
B	2.6	3.2	0.102	0.126
L2	1.5	1.8	0.059	0.071
θ	0	8	0	8
h	0	0.3	0	0.012
V	5.25	5.85	0.207	0.230
E	0.6	0.8	0.024	0.032



9 Dimensions(continues)

TO-220C PACKAGE OUTLINE DIMENSIONS

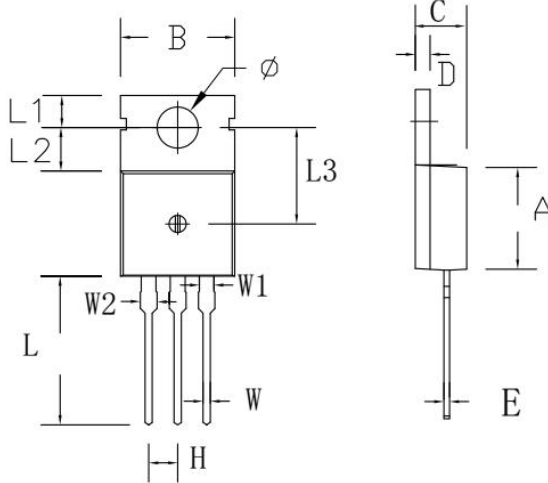

Symbol	Dimensions In Millimeters		Dimensions In Inches	
	min.	max.	min.	max.
A	8.80	9.30	0.346	0.366
B	9.70	10.30	0.382	0.406
C	4.25	4.75	0.167	0.187
D	1.20	1.45	0.047	0.057
E	0.40	0.60	0.016	0.024
H	2.54 TYP		0.100 TYP	
W	0.60	0.95	0.024	0.037
W1	1.05	1.45	0.041	0.057
W2	1.20	1.60	0.047	0.063
L	12.60	13.40	0.496	0.528
L1	2.45	2.95	0.096	0.116
L2	3.45	3.95	0.136	0.156
L3	8.15	8.65	0.321	0.341
Φ	3.50	3.90	0.138	0.154

TO-220F PACKAGE OUTLINE DIMENSIONS

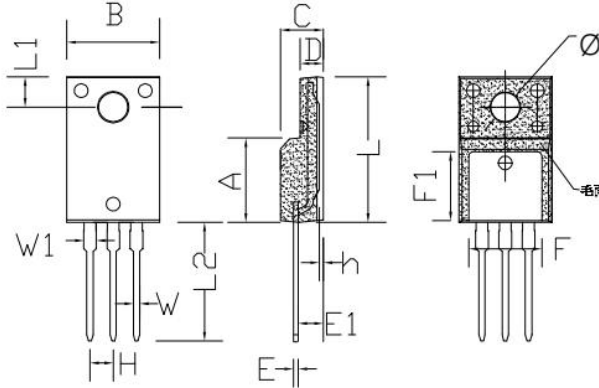

Symbol	Dimensions In Millimeters		Dimensions In Inches	
	min.	max.	min.	max.
A	8.80	9.30	0.346	0.366
B	10.00	10.50	0.394	0.413
C	4.30	4.90	0.169	0.193
D	2.30	2.70	0.091	0.106
L	15.55	16.15	0.612	0.636
h	0.40	0.60	0.016	0.024
L1	3.15	3.55	0.124	0.140
L2	12.65	13.35	0.498	0.526
W	0.70	0.90	0.028	0.035
W1	1.15	1.55	0.045	0.061
H	2.54 TYP		0.100 TYP	
E	0.48	0.53	0.019	0.021
Φ	2.90	3.40	0.114	0.134
E1	2.40	2.90	0.094	0.114
F	7.75	8.25	0.305	0.325
F1	7.35	7.85	0.289	0.309

9 Dimensions(continues)

TO-262 PACKAGE OUTLINE DIMENSIONS

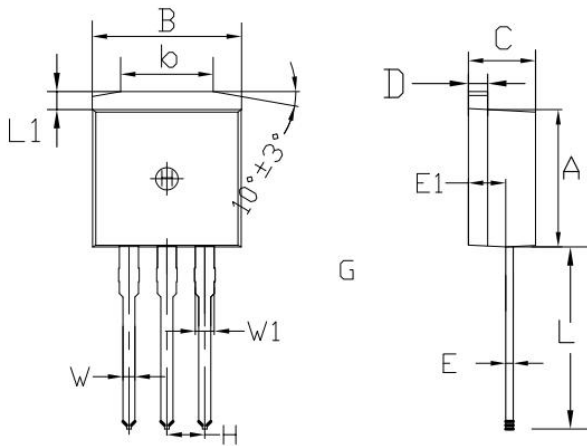

Symbol	Dimensions In Millimeters		Dimensions In Inches	
	min.	max.	min.	max.
A	8.80	9.30	0.346	0.366
B	9.70	10.30	0.382	0.406
C	4.25	4.75	0.167	0.187
D	1.20	1.45	0.047	0.057
E	0.40	0.60	0.016	0.024
L	12.25	13.75	0.482	0.541
L1	1.15	1.45	0.045	0.057
E1	2.4	2.6	0.0945	0.1024
W	0.80	0.82	0.0315	0.034
W1	1.20	1.30	0.047	0.051
H	2.54 TYP		0.200 TYP	
b	5.50	6.50	0.216	0.256

TO-263 PACKAGE OUTLINE DIMENSIONS

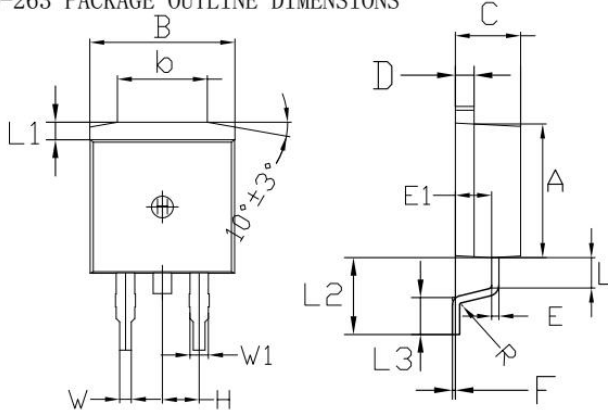

Symbol	Dimensions In Millimeters		Dimensions In Inches	
	min.	max.	min.	max.
A	8.80	9.30	0.346	0.366
B	9.70	10.30	0.382	0.406
C	4.25	4.75	0.167	0.187
D	1.20	1.45	0.047	0.057
E	0.40	0.60	0.016	0.024
L	1.90	2.30	0.075	0.091
L1	1.15	1.45	0.045	0.057
R	0.24	0.26	0.0095	0.0102
W	0.80	0.82	0.0315	0.0323
W1	1.20	1.30	0.047	0.051
H	2.54 TYP		0.200 TYP	
b	5.50	6.50	0.216	0.256
E1	2.4	2.6	0.0946	0.1024
L2	5.20	5.80	0.205	0.228
L3	2.20	3.20	0.087	0.126
F	0.03	0.23	0.0012	0.0091

## 10 Attentions

- Jiangsu Donghai Semiconductor Technology CO.,LTD. reserves the right to change the specification without prior notice! The customer should obtain the latest version of the information before making the order and verify that the information is complete and up to date.
- It is the responsibility of the purchaser for any failure or failure of any semiconductor product under certain conditions. It is the responsibility of the purchaser to comply with safety standards and to take safety measures in the system design and machine manufacturing of Donghai products in order to avoid potential risk of failure. Injury or property damage.
- Product promotion is endless, our company will be dedicated to provide customers with better products.

## 11 Appendix

Revision history:

Date	REV.	Description	Page
2021.08.12	1.0	Original	