

25A 650V N-channel Super Junction Power MOSFET

1 Description

This N-channel enhanced vdmofets, is using advanced super junction technology and design to provide excellent Rdson with low gate charge. Which accords with the RoHS standard.

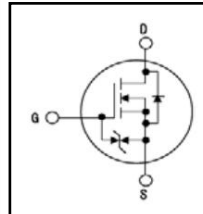

$V_{DSS} = 650V$
$R_{DS(on)} (TYP) = 110m\Omega$
$I_D = 25A$

2 Features

- Fast switching
- Low on resistance
- Low gate charge
- Low reverse transfer capacitances
- 100% single pulse avalanche energy test
- 100% ΔV_{DS} test

3 Applications

- Power factor correction(PFC).
- Switched mode power supplies(SMPS).
- Uninterruptible power supply(UPS).
- AC to DC Converters
- Telecom, Solar

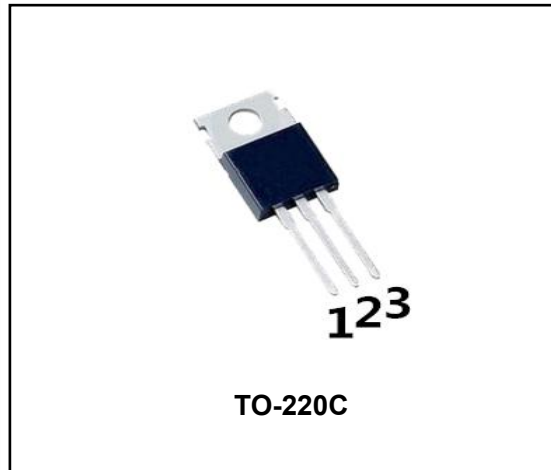

4 Electrical Characteristics

4.1 Absolute Maximum Rating (Tc=25°C, unless otherwise noted)

Parameter	Symbol	Rating	Units
Drian-to-Source Voltage	V_{DSS}	650	V
Gate-to-Source Voltage	V_{GSS}	± 20	V
Continuous Drain Current	I_D	$T_C=25^\circ C$	25
		$T_C=100^\circ C$	15.8
Pulsed Drain Current ⁽¹⁾	I_{DM}	75	A
Single Pulse Avalanche Energy ⁽⁴⁾	E_{AS}	455	mJ
Repetitive Avalanche Current ⁽⁴⁾	I_{AR}	3.2	A
MOSFET dv/dt ruggedness, $V_{DS}=0\dots 400V$	dv/dt	50	V/ns
Reverse diode dv/dt, $V_{DS}=0\dots 400V, I_{DS}\leq I_D$	dv/dt	15	V/ns
Power Dissipation	P_{tot}	$T_a=25^\circ C$	2
		$T_C=25^\circ C$	180
Gate-Source ESD (Human Body Model, 100 pF, 1.5kV)	$V_{ESD(G-S)}$	2000	V
Junction Temperature Range	T_j	-55~150	°C
Storage Temperature Range	T_{stg}	-55~150	°C

4.2 Thermal Characteristics

Parameter	Symbol	Rating	Unit
Thermal Resistance, Junction to Case-sink	R_{thJC}	0.7	°C/W
Thermal Resistance, Junction to Ambient	R_{thJA}	62.5	°C/W

4.3 Electrical Characteristics (T_c=25°C, unless otherwise noted)

Parameter	Symbol	Test Condition	Value			Units
			Min	Typ	Max	
Off Characteristics						
Drain-to-Source Breakdown Voltage	BV _{DSS}	I _D =250μA, V _{GS} =0V	650	--	--	V
Drain-to-Source Leakage Current	I _{DSS}	V _{DS} =650V, V _{GS} =0V, T _C =25°C	--	--	2	μA
		V _{DS} =650V, V _{GS} =0V, T _C =150°C	--	--	1000	μA
Gate-to-Source Leakage Current	I _{GSS}	V _{GS} =±20V	--	--	±1000	nA
On Characteristics						
Gate Threshold Voltage	V _{GS(th)}	V _{DS} =V _{GS} , I _D =250μA	2.5	--	4.5	V
Drain-to-Source on-state Resistance	R _{DS(on)}	V _{GS} =10V, I _D =12.5A	--	110	125	mΩ
Dynamic Characteristics						
Input Capacitance	C _{iss}	V _{GS} =0V, V _{DS} =400V, f=1.0MHz	--	2840	--	pF
Output Capacitance	C _{oss}		--	60	--	
Reverse Transfer Capacitance	C _{rss}		--	3.8	--	
Switching Characteristics						
Turn-on Delay Time	t _{d(on)}	I _D =14.3A, V _{DD} =325V, V _{GS} =10V, R _G =25Ω	--	56	--	nS
Turn-on Rise Time	t _r		--	31	--	
Turn-off Delay Time	t _{d(off)}		--	250	--	
Turn-off Fall Time	t _f		--	20	--	
Total Gate Charge	Q _g	I _D =14.3A, V _{DD} =520V, V _{GS} =10V	--	65	--	nC
Gate-to-Source Charge	Q _{gs}		--	12	--	
Gate-to-Drain("Miller") Charge	Q _{gd}		--	20	--	
Drain-Source Diode Characteristics						
Diode Forward Voltage ⁽³⁾	V _{FSD}	V _{GS} =0V, I _S =14.3A	--	--	1.2	V
Diode Forward Current	I _S		--	--	25	A
Reverse Recovery Time ⁽³⁾	t _{rr}	T _J =25°C, I _F =14.3A, dI _F /dt=100A/μS, V _R =400V	--	150	--	nS
Reverse Recovery Charge ⁽³⁾	Q _{rr}		--	1000	--	nC

Notes:

- 1: Repetitive rating, pulse width limited by maximum junction temperature.
- 2: Surface mounted on FR4 Board, t_≤10sec.
- 3: Pulse width ≤ 300μs, duty cycle ≤ 2%.
- 4: L=10mH, I_D=9.6A, V_{DD}=100V, V_{GS}=10V, R_G=25Ω, V_{GATE}=650V, Start T_J=25°C.

5 Typical characteristics diagrams

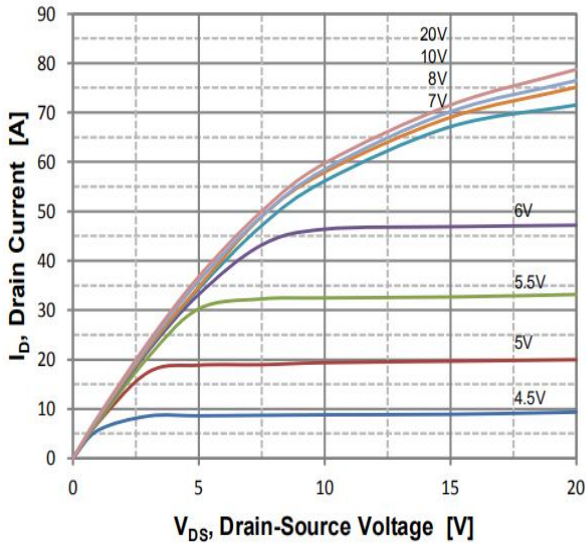

Figure 1. On Region Characteristics

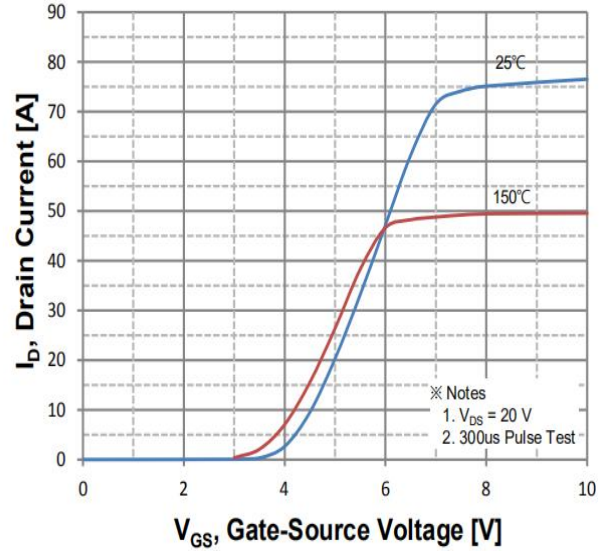

Figure 2. Transfer Characteristics

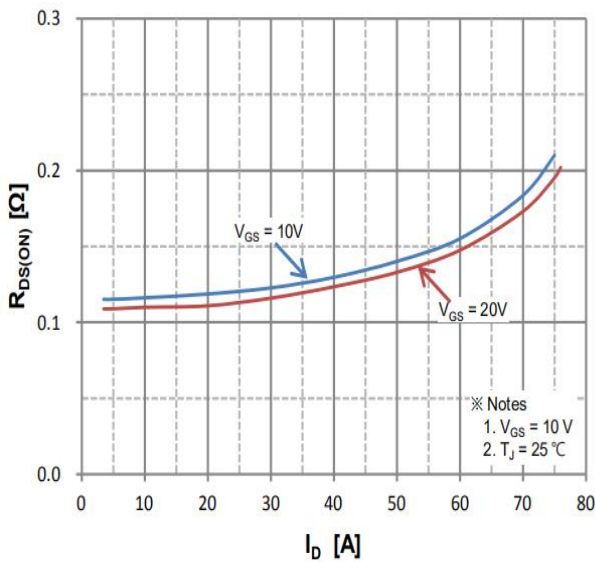

Figure 3. On Resistance Variation vs Drain Current and Gate Voltage

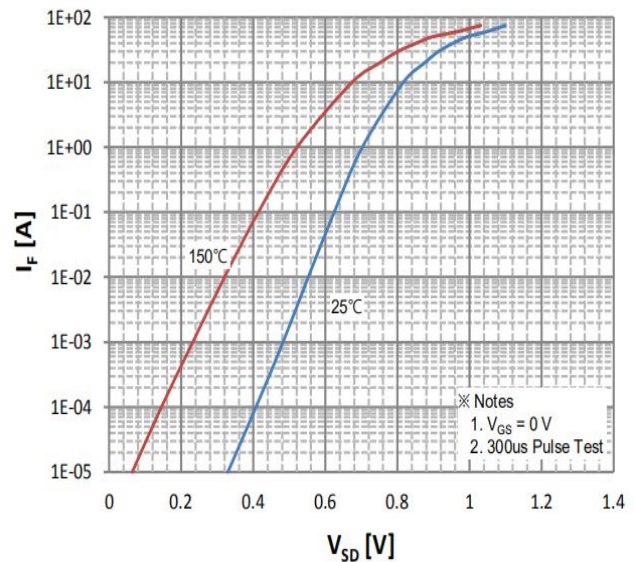

Figure 4. Body Diode Forward Voltage Variation with Source Current and Temperature

5 Typical characteristics diagrams(continues)

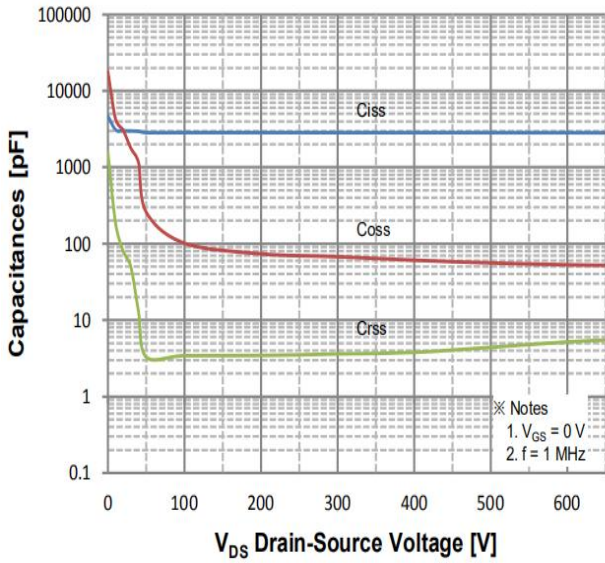

Figure 5. Capacitance Characteristics

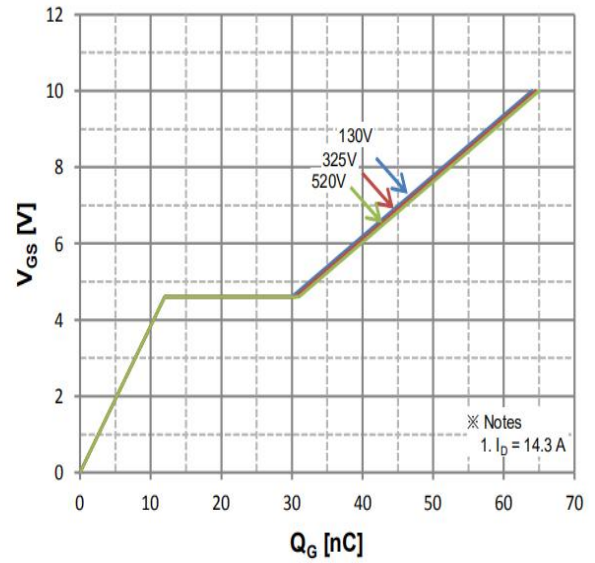

Figure 6. Gate Charge Characteristics

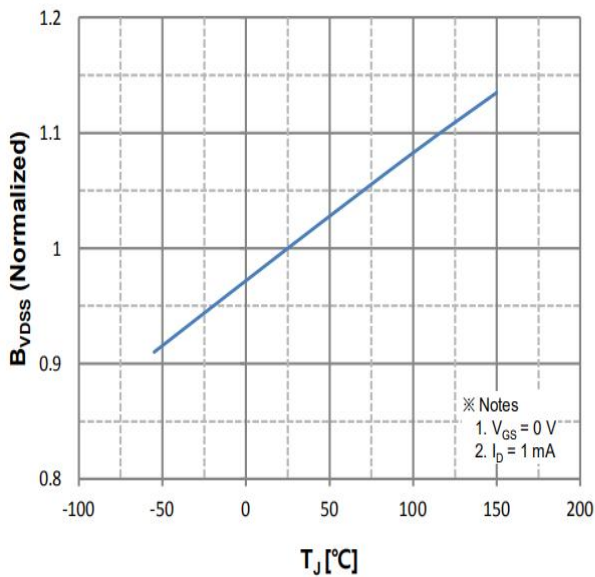

Figure 7. Breakdown Voltage Variation vs. Temperature

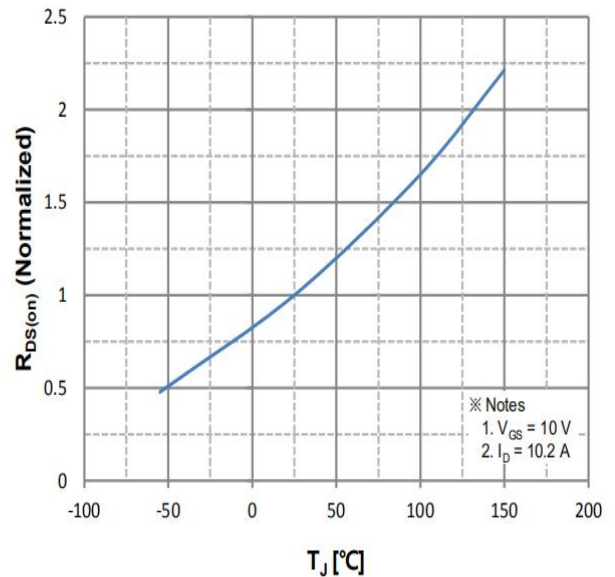

Figure 8. On-Resistance Variation vs. Temperature

5 Typical characteristics diagrams(continues)

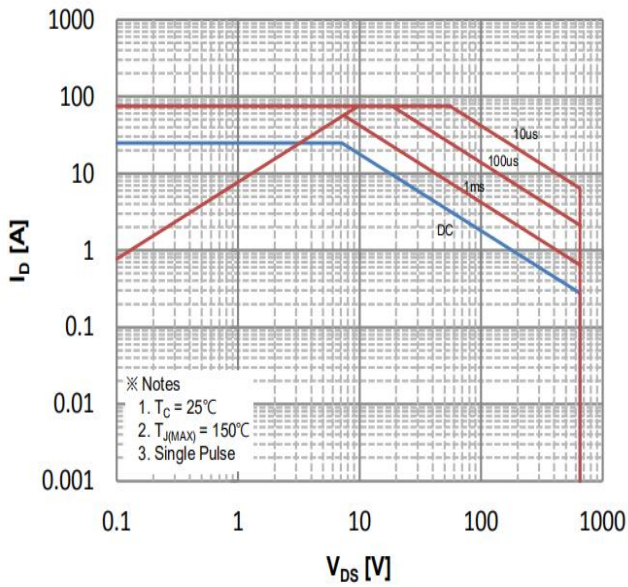

Figure 9. Maximum Safe Operating Area

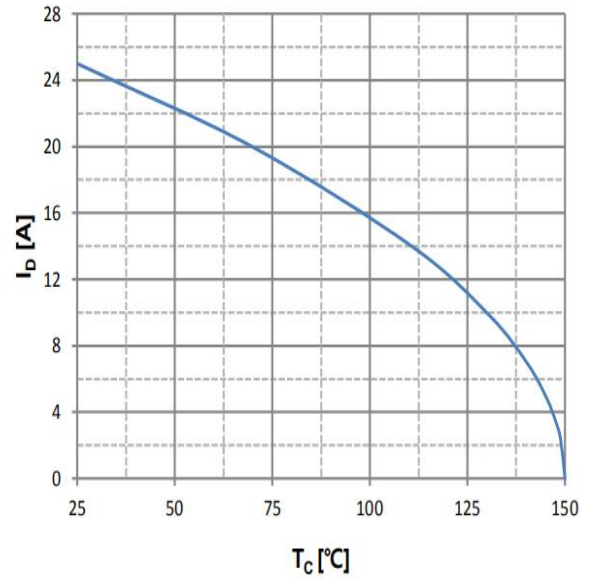

Figure 10. Maximum Drain Current vs. Case Temperature

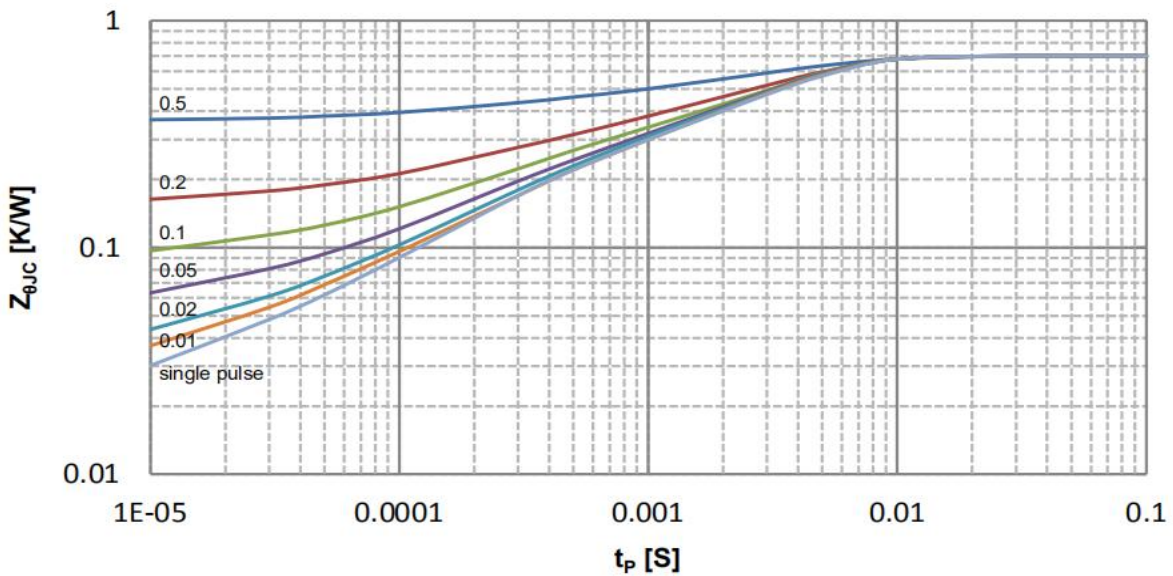
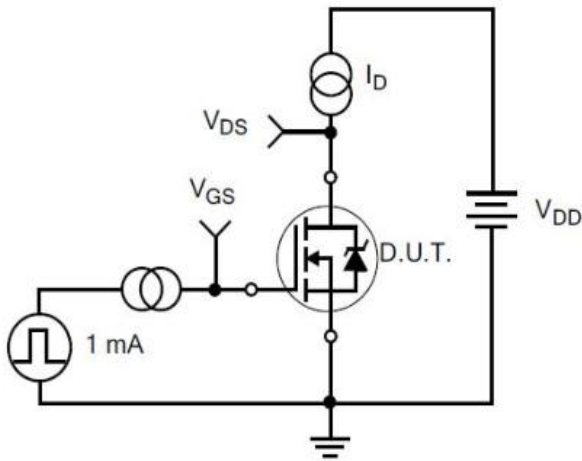
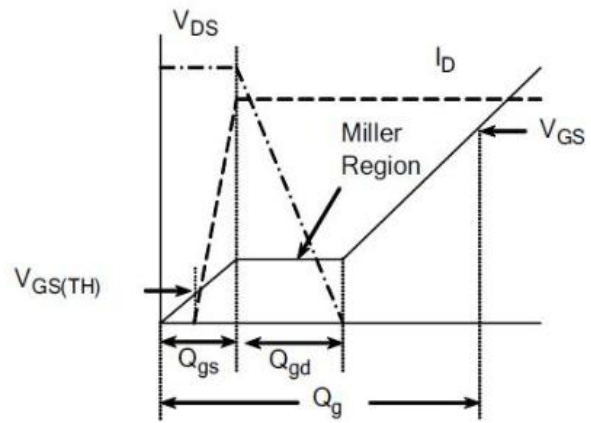

Figure 11. Transient Thermal Response Curve

6 Typical Test Circuit and Waveform



1) Gate Charge Test Circuit



2) . Gate Charge Waveform

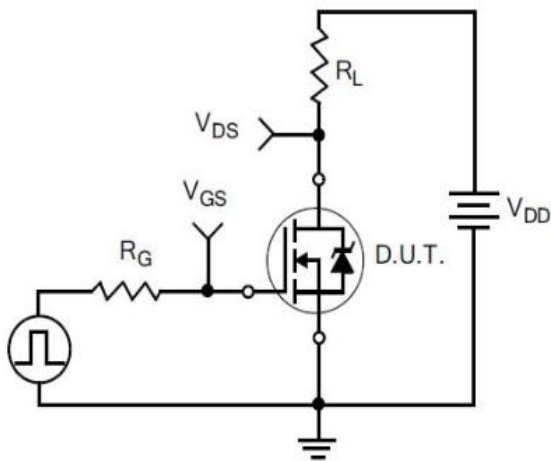

3) Resistive Switching Test Circuit

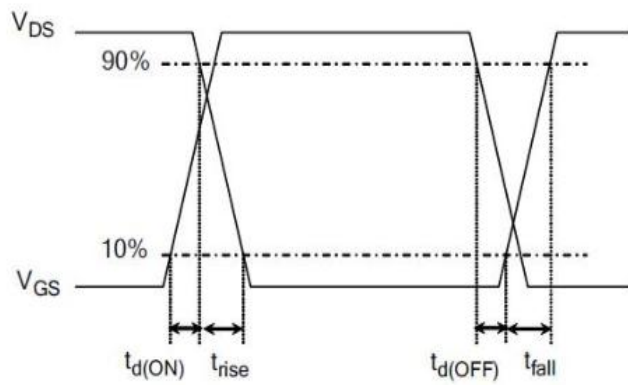

4) Resistive Switching Waveforms

6 Typical Test Circuit and Waveform(continues)

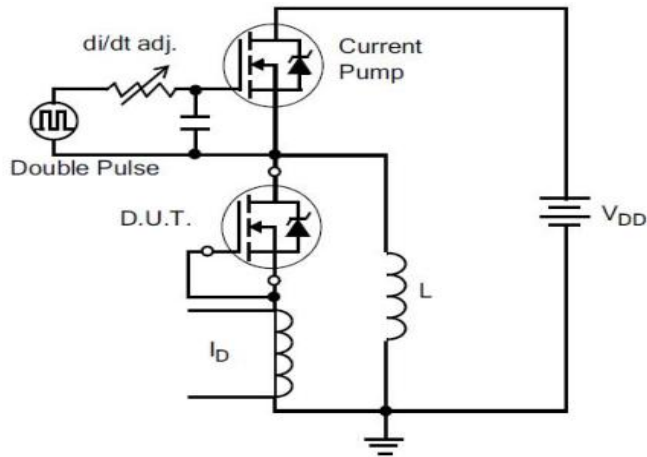

5) Diode Reverse Recovery Test Circuit

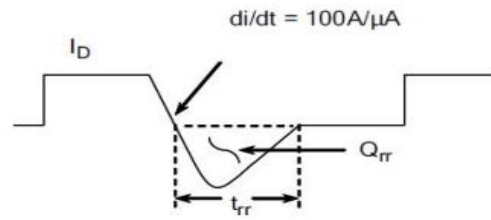

6) Diode Reverse Recovery Waveform

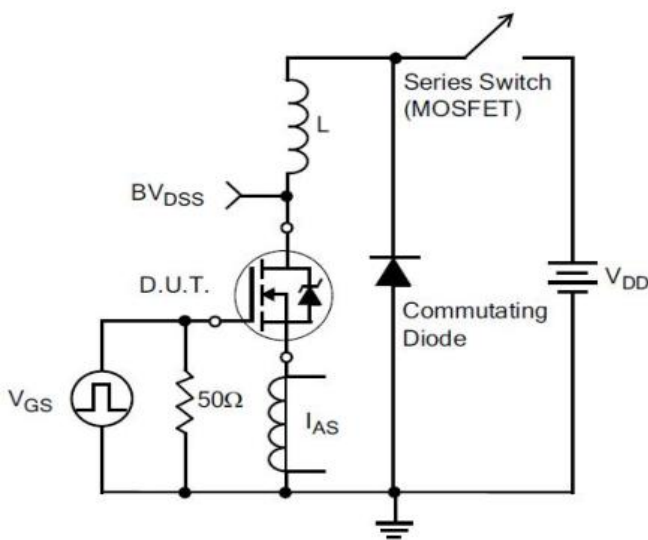

7) . Unclamped Inductive Switching Test Circuit

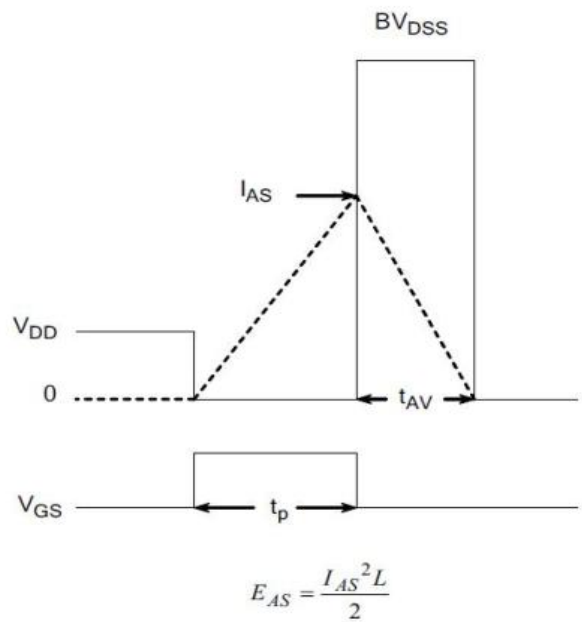

8) Unclamped Inductive Switching Waveforms

7 Product Names Rules

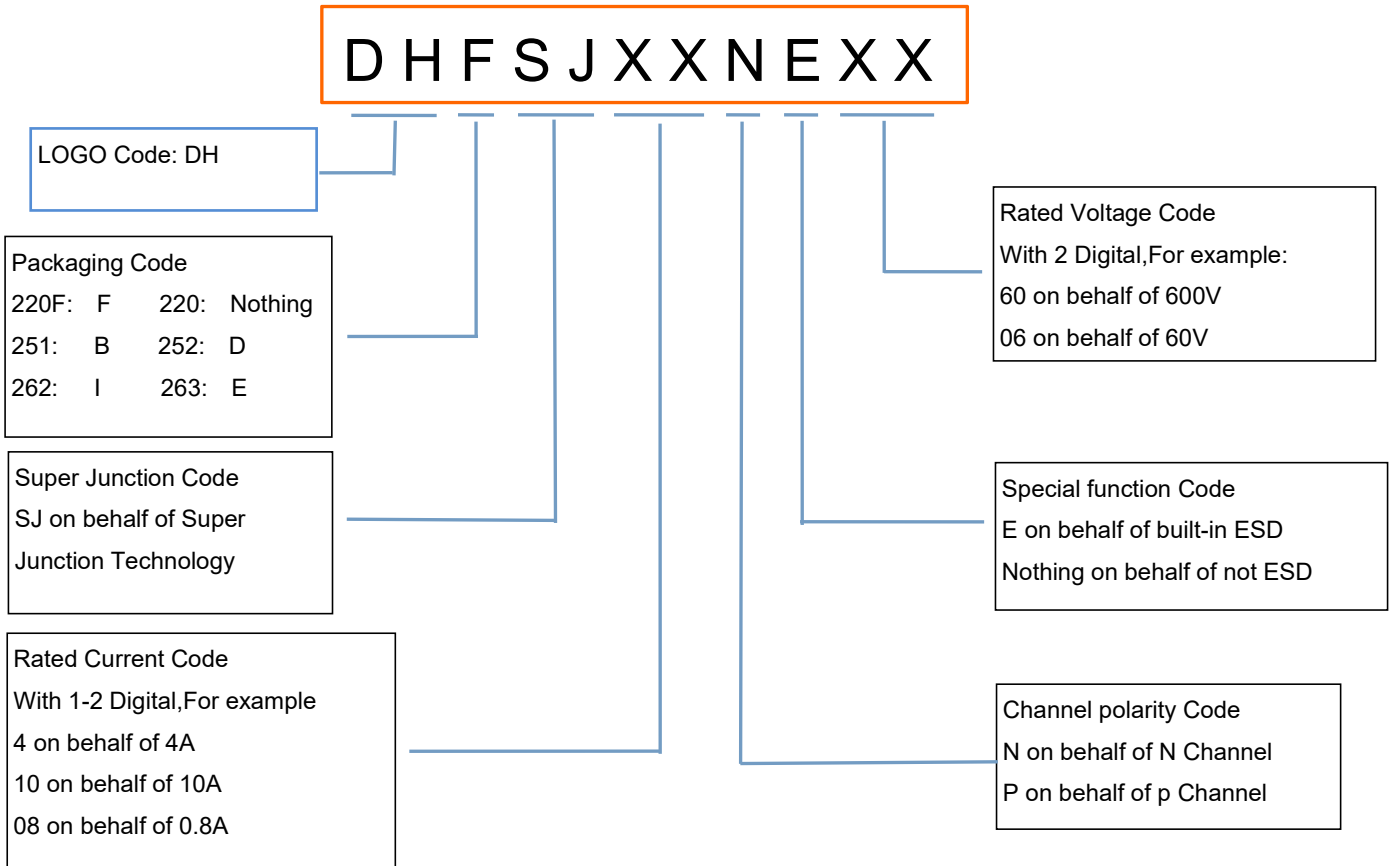

8 Product Specifications and Packaging Models

Product Model	Package Type	Mark Name	RoHS	Package	Quantity
DHSJ25N65F	TO-220	DHSJ25N65F	Pb-free	Tube	1000/box

9 Dimensions

TO-220C PACKAGE OUTLINE DIMENSIONS

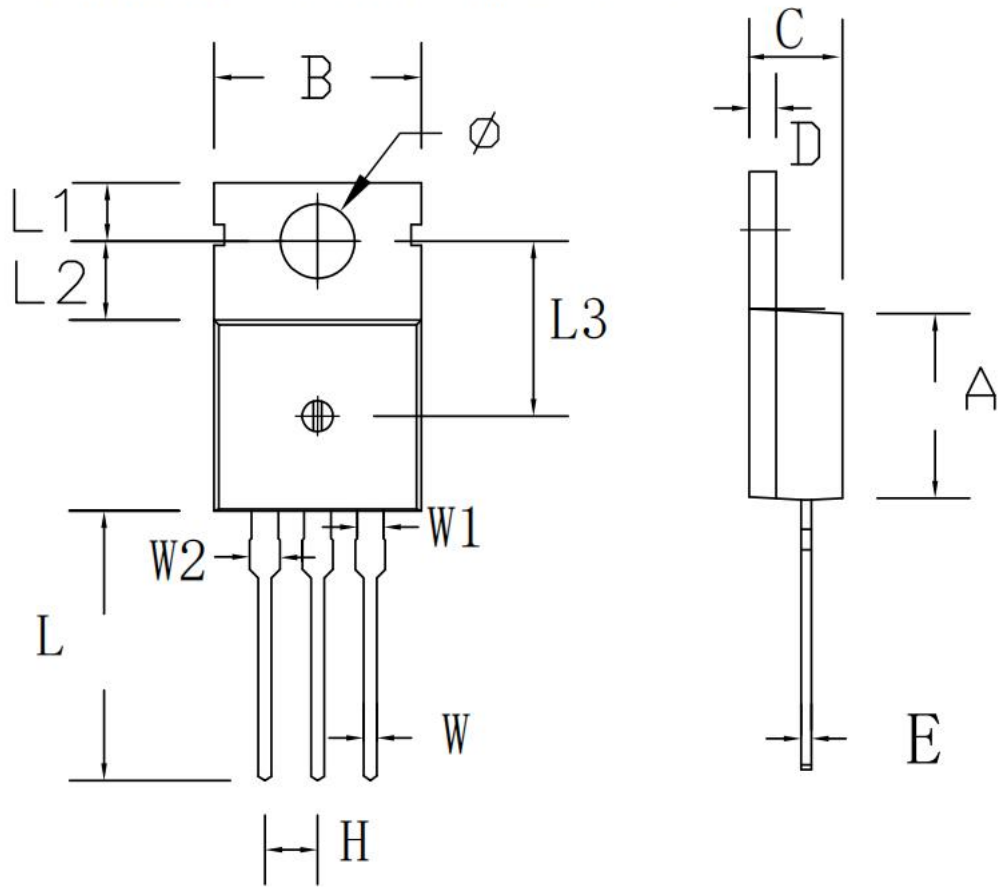

Symbol	Dimensions In Millimeters		Dimensions In Inches	
	min.	max.	min.	max.
A	8.80	9.30	0.346	0.366
B	9.70	10.30	0.382	0.406
C	4.30	4.75	0.169	0.187
D	1.20	1.45	0.047	0.057
E	0.40	0.60	0.016	0.024
H	2.54 TYP		0.100 TYP	
W	0.69	0.95	0.027	0.037
W1	1.05	1.45	0.041	0.057
W2	1.20	1.60	0.047	0.063
L	12.60	13.40	0.496	0.528
L1	2.45	2.95	0.096	0.116
L2	3.45	3.95	0.136	0.156
L3	8.15	8.65	0.321	0.341
Φ	3.50	3.90	0.138	0.154

10 Attentions

- Jiangsu Donghai Semiconductor Technology CO.,LTD. reserves the right to change the specification without prior notice! The customer should obtain the latest version of the information before making the order and verify that the information is complete and up to date.
- It is the responsibility of the purchaser for any failure or failure of any semiconductor product under certain conditions. It is the responsibility of the purchaser to comply with safety standards and to take safety measures in the system design and machine manufacturing of Donghai products in order to avoid potential risk of failure. Injury or property damage.
- Product promotion is endless, our company will be dedicated to provide customers with better products.

11 Appendix

Revision history:

Date	REV.	Description	Page
2022.11.15	1.0	Original	