

41A 650V N-channel SiC Power MOSFET

1 Description

This product family offers state of the art performance. It is designed for high frequency applications where high efficiency and high reliability are required.

2 Features

- Higher System Efficiency
- Reduced Cooling Requirements
- Increased Power Density
- Increased System Switching Frequency

3 Applications

- Power Supplies.
- High Voltage DC/DC Converters.
- Motor Drives.
- Switch Mode Power Supplies
- Pulsed Power applications

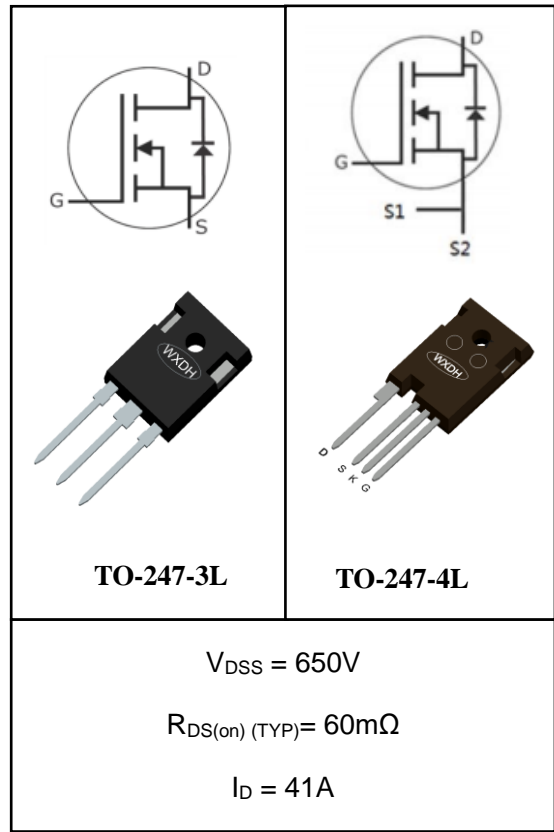

4 Electrical Characteristics

4.1 Absolute Maximum Rating ($T_c=25^\circ C$, unless otherwise noted)

Parameter	Symbol	Test Conditions	Value	Units
Drain-to-Source Voltage	V_{DSmax}	$V_{GS}=0V, I_D=100\mu A$	650	V
Gate-Source Voltage	V_{GSmax}	Absolute maximum values	-8/+22	V
Gate-Source Voltage	V_{GSop}	Recommended operational values	-4/+18	V
Continuous Drain Current	I_D	$V_{GS}=18V, T_C=25^\circ C$	41	A
		$V_{GS}=18V, T_C=100^\circ C$	99	A
Pulsed Drain Current ⁽¹⁾	$I_{D(PULSE)}$	Pulse width t_p limited by T_{Jmax}	99	A
Power Dissipation	P_D	$T_c=25^\circ C, T_J=175^\circ C$	166	W
Junction Temperature Range	T_j		-40~175	$^\circ C$
Storage Temperature Range	T_{stg}		-40~175	$^\circ C$

4.2 Thermal Characteristics

Parameter	Symbol	Rating	Unit
Thermal Resistance, Junction to Case-sink	R_{thJC}	0.9	$^\circ C/W$
Thermal Resistance, Junction to Ambient	R_{thJA}	40	$^\circ C/W$

4.3 Electrical Characteristics (T_c=25°C, unless otherwise noted)

Parameter	Symbol	Test Condition	Value			Units
			Min	Typ	Max	
Drain-to-Source Breakdown Voltage	BV _{DSS}	I _D =100μA, V _{GS} =0V	650	---	---	V
Zero Gate Voltage Drain Current	I _{DSS}	V _{DS} =650V, V _{GS} =0V	---	1	50	μA
Gate-to-Source Leakage	I _{GSS+}	V _{DS} =0V, V _{GS} =18V	---	10	250	nA
Gate Threshold Voltage	V _{GS(th)}	V _{DS} =V _{GS} , I _D =5mA	1.8	2.6	4.0	V
		V _{DS} =V _{GS} , I _D =5mA, T _J =175°C	---	1.8	---	V
Drain-to-Source on-state Resistance	R _{DSON}	V _{GS} =18V, I _D =13.2A	42	60	79	mΩ
		V _{GS} =18V, I _D =13.2A, T _J =175°C	---	75	---	
Input Capacitance	C _{ISS}	V _{GS} =0V, V _{DS} =600V, f=1.0MHz, V _{AC} =25mV	---	830	---	pF
Output Capacitance	C _{OSS}		---	82	---	
Reverse Transfer Capacitance	C _{RSS}		---	14	---	
Turn-On Switching Energy	E _{ON}	V _{DS} =400V, V _{GS} =-4V/18V I _D =13.2A, R _{G(ext)} =2.5Ω, L=200μH	---	140	---	μJ
Turn-Off Switching Energy	E _{OFF}		---	52	---	
Turn-on Delay Time	t _{d(on)}	V _{DS} =400V, V _{GS} =-4V/18V, I _D =13.2A, R _{G(ext)} =2.5Ω, R _L =30Ω	---	8	---	nS
Turn-on Rise Time	t _r		---	9	---	
Turn-off Delay Time	t _{d(off)}		---	21	---	
Turn-off Fall Time	t _f		---	8	---	
Internal Gate Resistance	R _{G(int)}	f=1MHz, V _{AC} =25mV	---	6	---	Ω
Total Gate Charge	Q _g	V _{DS} =400V, V _{GS} =-4V/18V, I _D =13.2A	---	50	---	nC
Gate-to-Source Charge	Q _{gs}		---	13	---	
Gate-to-Drain("Miller") Charge	Q _{gd}		---	12	---	
Drain-Source Diode Characteristics						
Diode Forward Voltage ⁽³⁾	V _{SD}	V _{GS} =-4V, I _{SD} =6.6A	---	4.2	---	V
		V _{GS} =-4V, I _{SD} =6.6A, T _J =175°C	---	3.8	---	V
Diode Forward Current	I _S	V _{GS} =-4V, T _C =25°C	---	---	23	A
Reverse Recovery Time ⁽³⁾	t _{rr}	V _R =400V, I _{SD} =13.2A	---	28	---	nS
Reverse Recovery Charge ⁽³⁾	Q _{rr}		---	47	---	nC
Peak Reverse Recovery Current	I _{rrm}		---	3	---	A

Notes:

- 1: Repetitive rating, pulse width limited by maximum junction temperature.
- 2: Surface mounted on FR4 Board, t_s≤10sec.
- 3: Pulse width ≤ 300μs, duty cycle ≤ 2%.

5 Typical characteristics diagrams

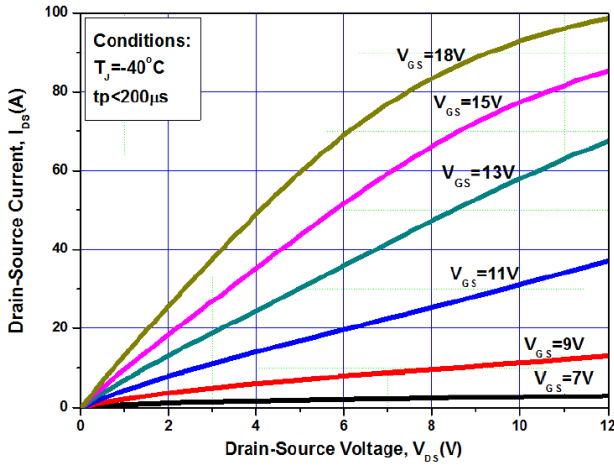

Figure 1. Output Characteristics $T_j = -40^\circ\text{C}$

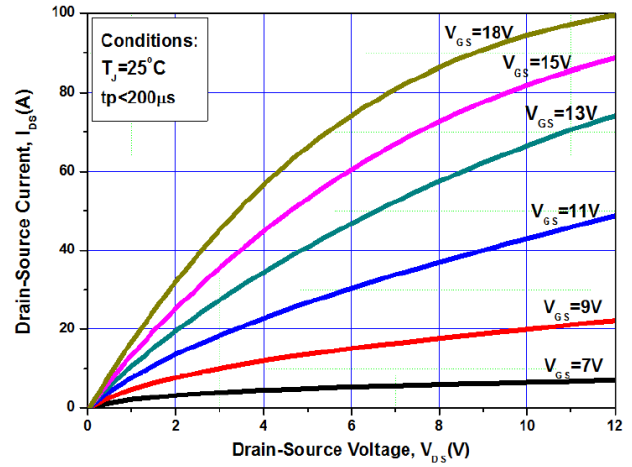

Figure 2. Output Characteristics $T_j = 25^\circ\text{C}$

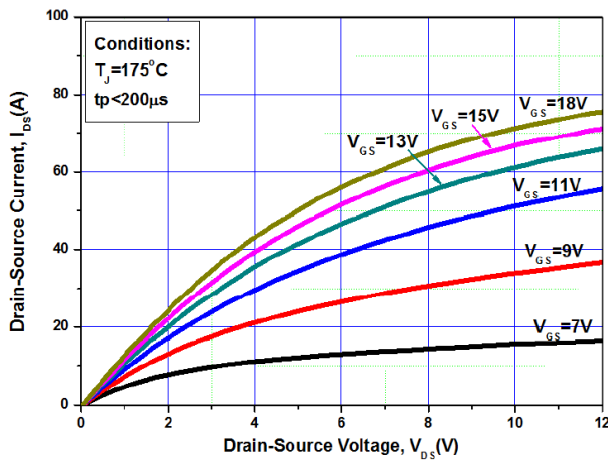

Figure 3. Output Characteristics $T_j = 175^\circ\text{C}$

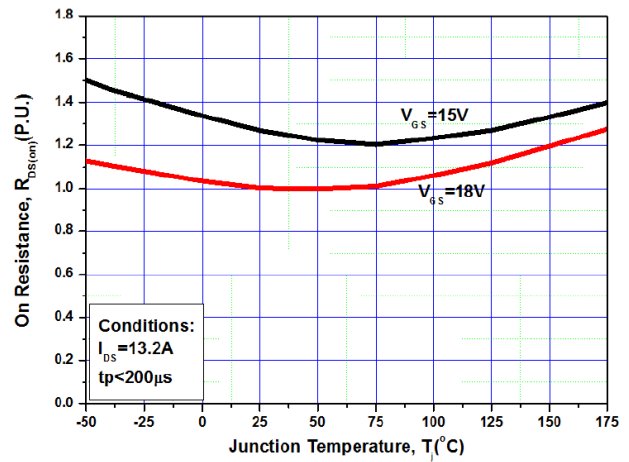

Figure 4. Normalized On-Resistance vs. Temperature

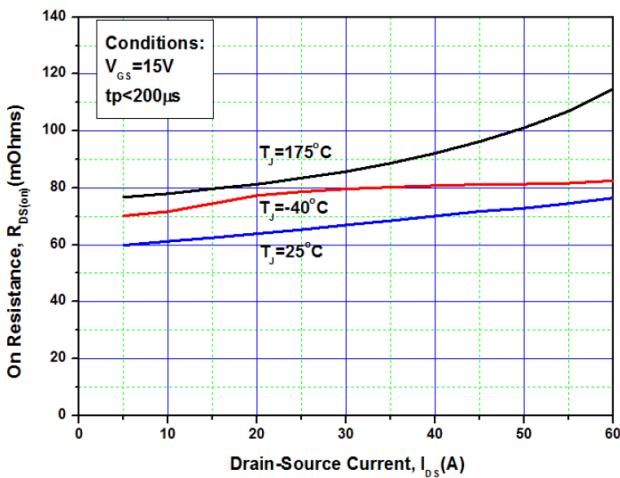

Figure 5. On-Resistance vs. Drain Current For Various Temperatures

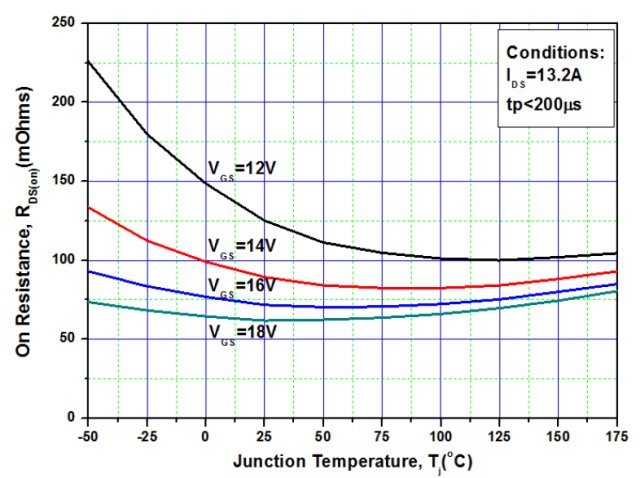

Figure 6. On-Resistance vs. Temperature For Various Gate Voltage

5 Typical characteristics diagrams(continues)

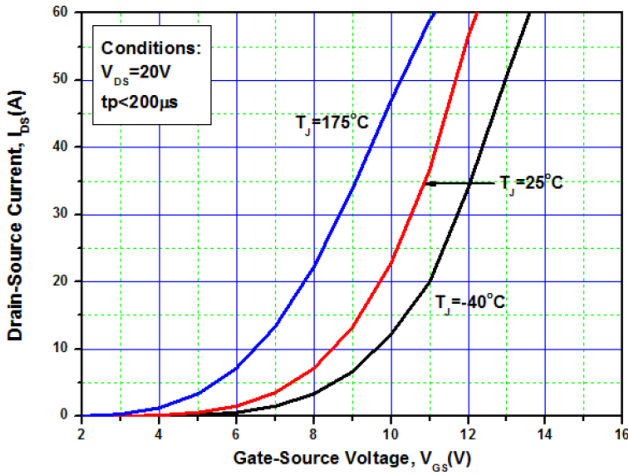

Figure 7. Transfer Characteristic for Various Junction Temperatures

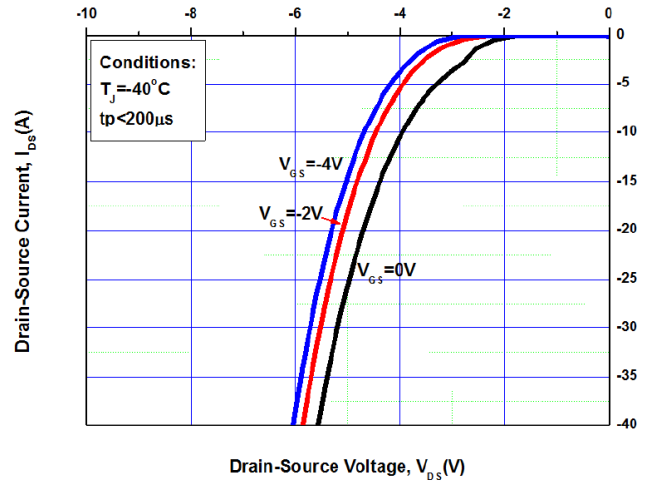

Figure 8. Body Diode Characteristic at -40°C

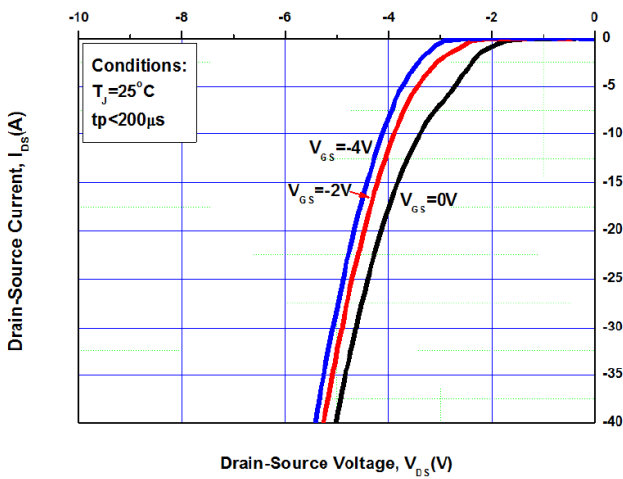

Figure 9. Body Diode Characteristic at 25°C

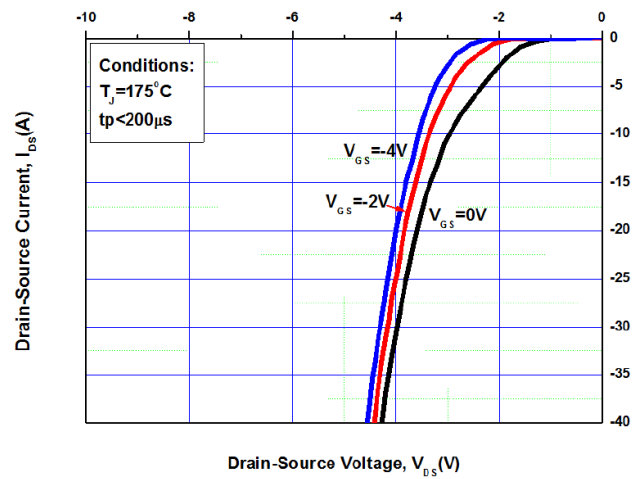

Figure 10. Body Diode Characteristic at 150°C

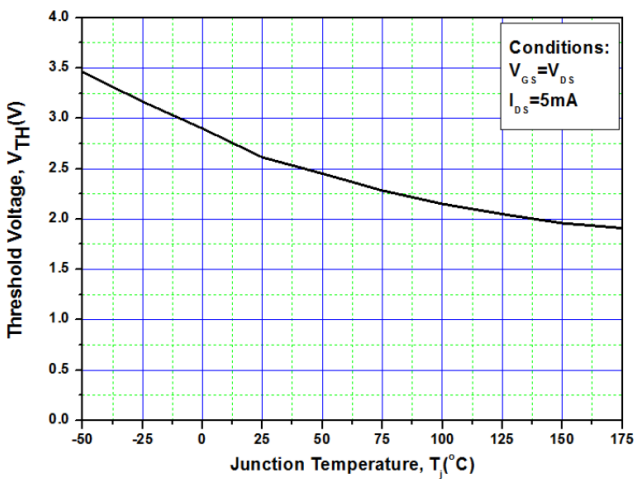

Figure 11. Threshold Voltage vs. Temperature

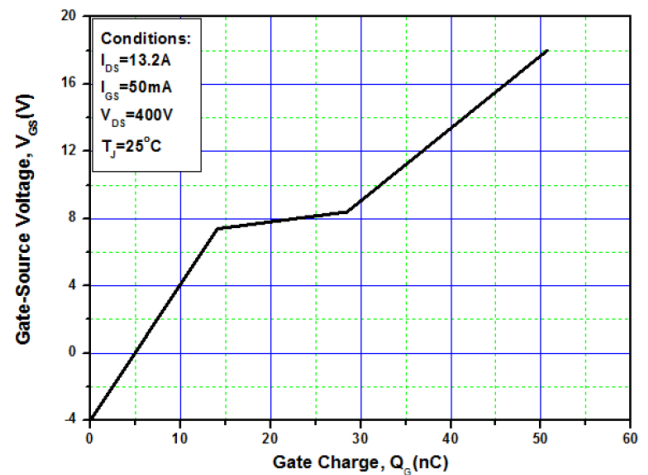

Figure 12. Gate Charge Characteristics

5 Typical characteristics diagrams(continues)

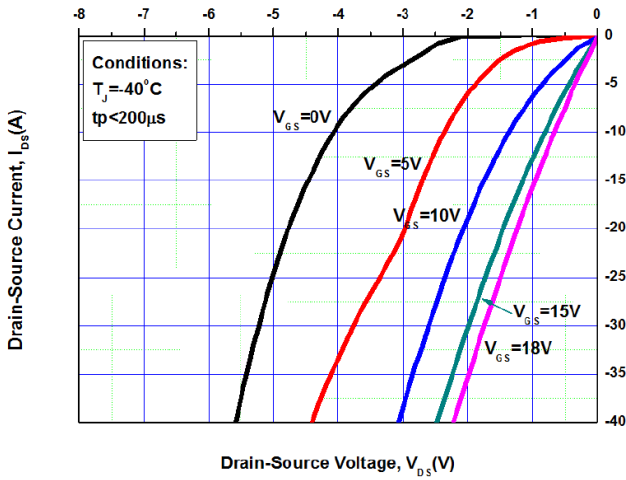

Figure 13. 3rd Quadrant Characteristic at -40°C

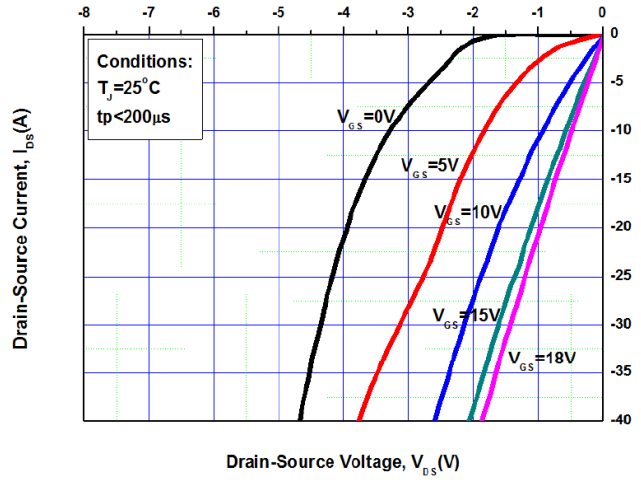

Figure 14. 3rd Quadrant Characteristic at 25°C

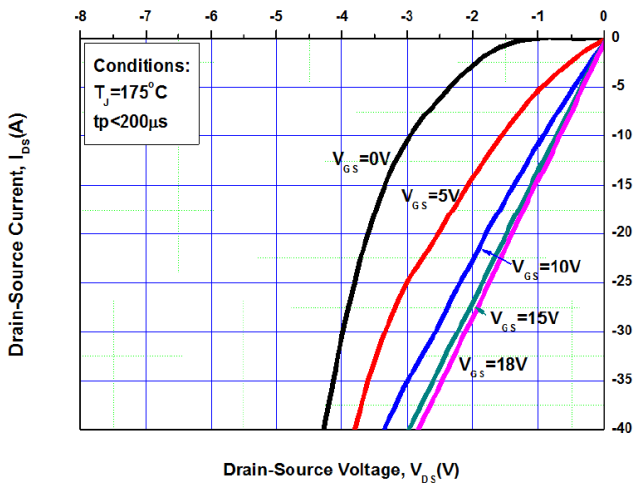

Figure 15. 3rd Quadrant Characteristic at 175°C

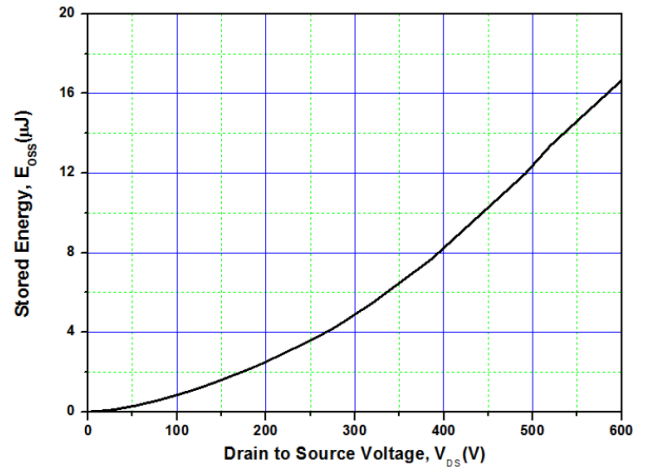

Figure 16. Output Capacitor Stored Energy

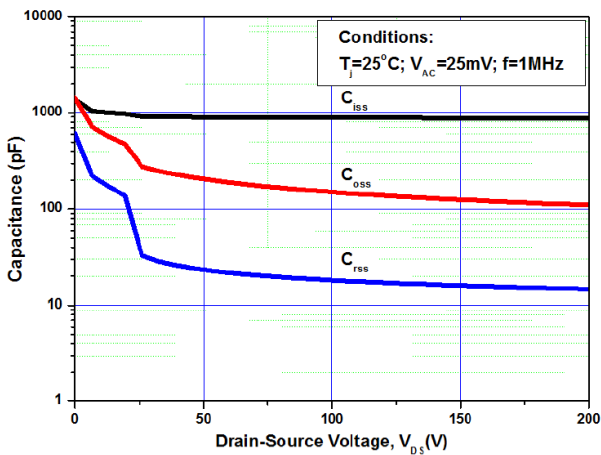

Figure 17. Capacitances vs. Drain-Source Voltage (0 - 200V)

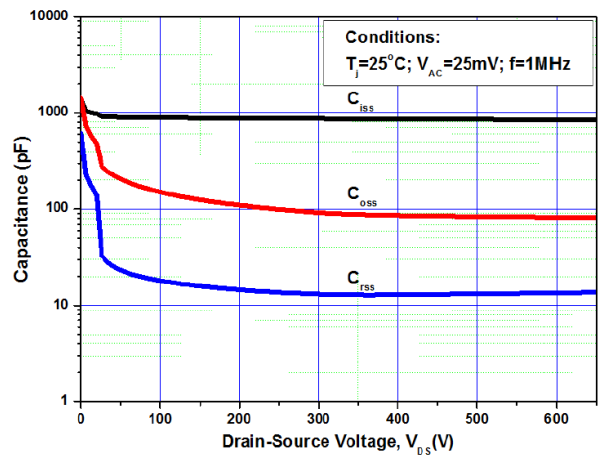

Figure 18. Capacitances vs. Drain-Source Voltage (0 - 650V)

5 Typical characteristics diagrams(continues)

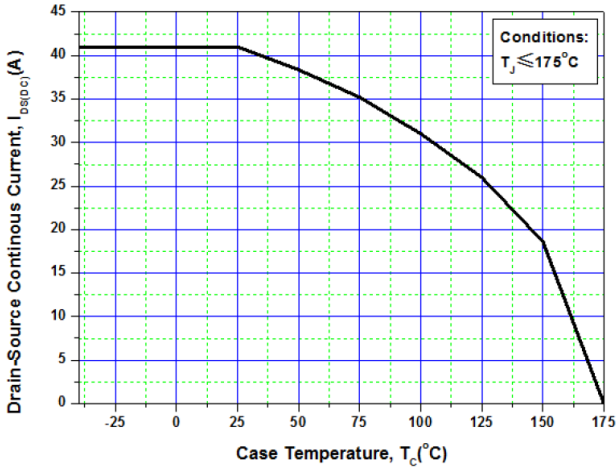

Figure 19. Continuous Drain Current Derating vs. Case Temperature

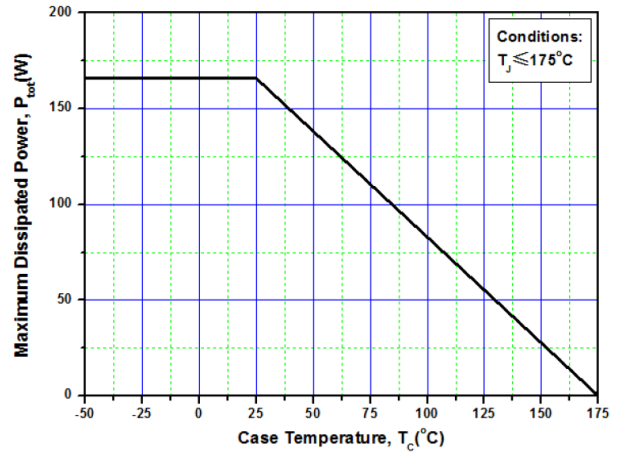

Figure 20. Maximum Power Dissipation Derating vs. Case Temperature

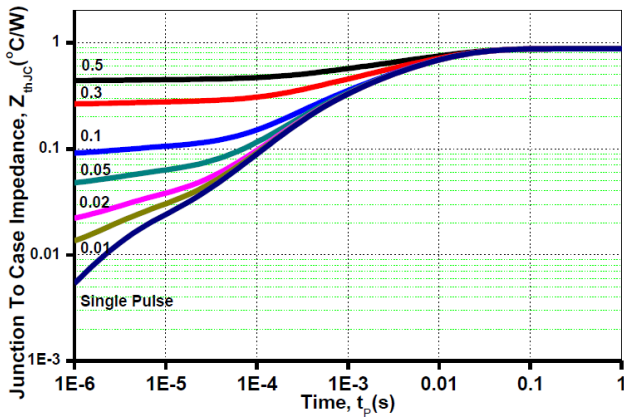

Figure 21. Transient Thermal Impedance (Junction - Case)

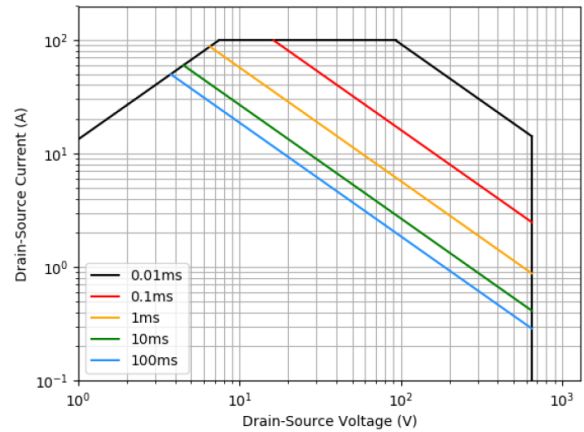

Figure 22. Safe Operating Area

6 Product Specifications and Packaging Models

Product Model	Package Type	Mark Name	RoHS	Package	Quantity
DCC060M65G2	TO-247-3L	DCC060M65G2	Pb-free	Tube	300/box
DCCF060M65G2	TO-247-4L	DCCF060M65G2	Pb-free	Tube	300/box

7 Dimensions

TO-247-3L PACK OUTLINE DIMENSIONS

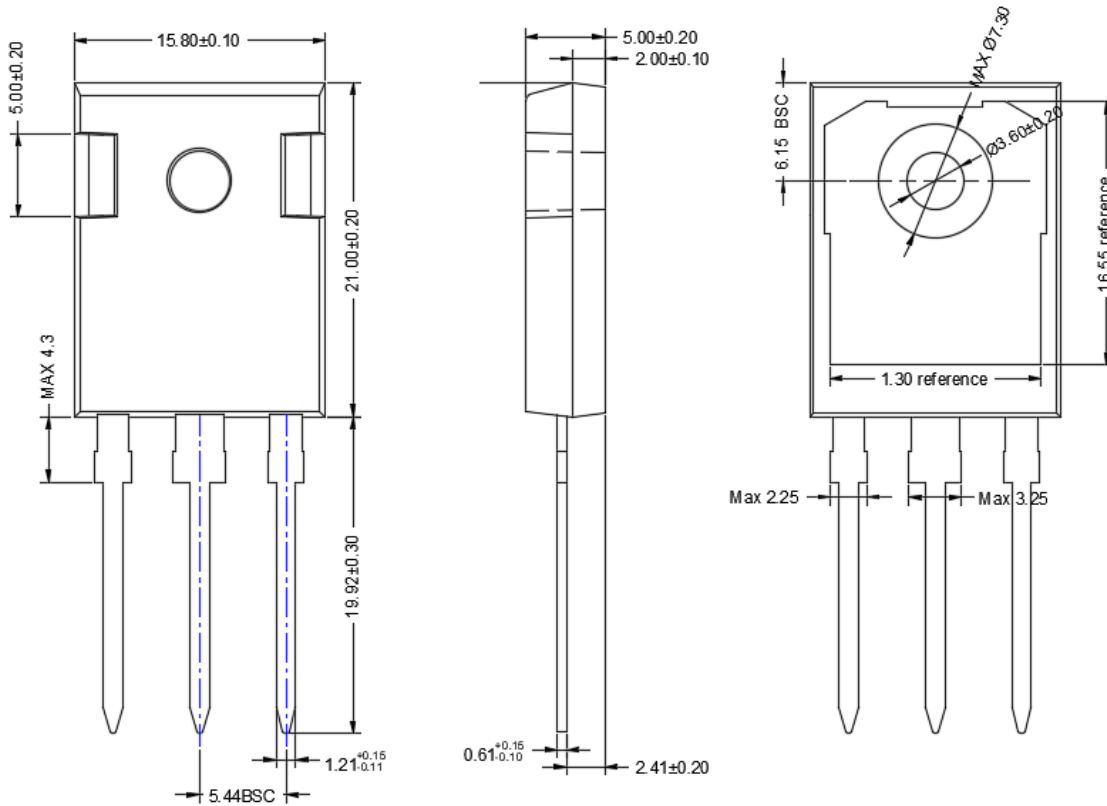

TO-247-4L PACK OUTLINE DIMENSIONS

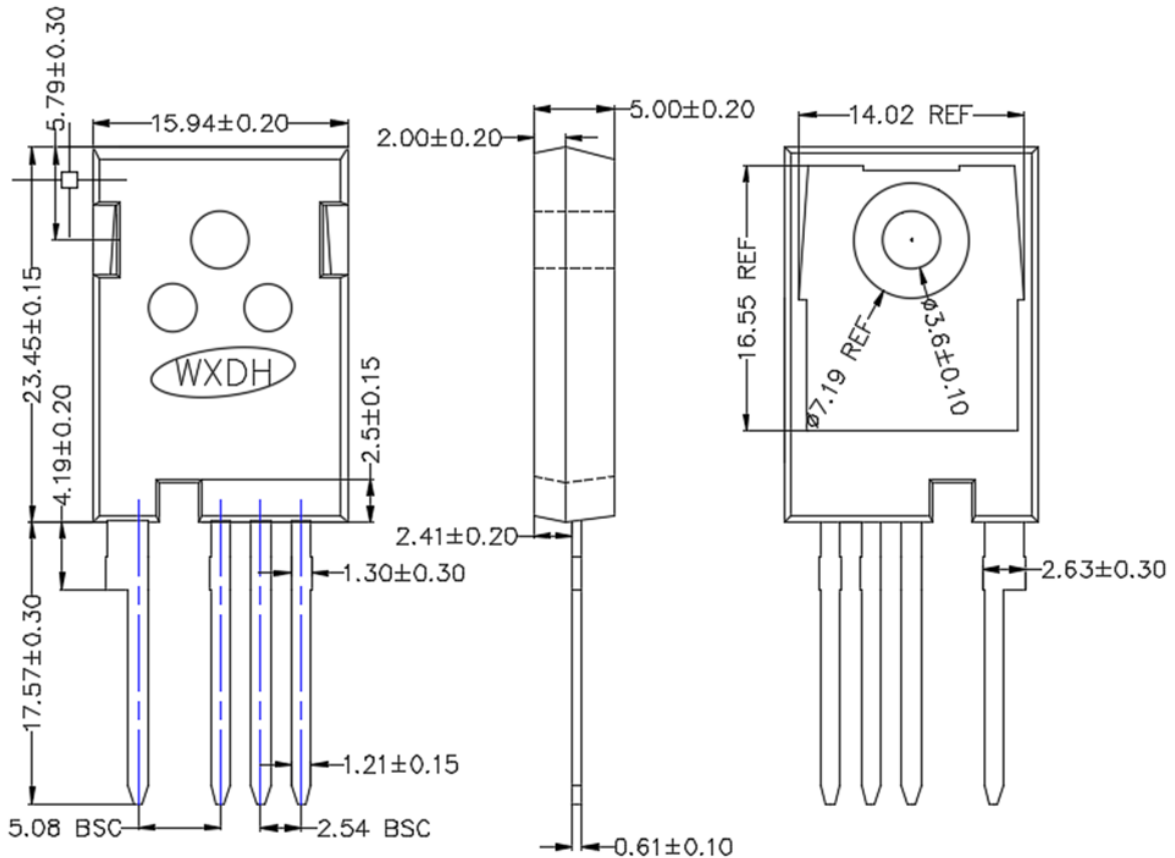

8 Attentions

- Jiangsu Donghai Semiconductor Technology CO.,LTD. reserves the right to change the specification without prior notice! The customer should obtain the latest version of the information before making the order and verify that the information is complete and up to date.
- It is the responsibility of the purchaser for any failure or failure of any semiconductor product under certain conditions. It is the responsibility of the purchaser to comply with safety standards and to take safety measures in the system design and machine manufacturing of Donghai products in order to avoid potential risk of failure. Injury or property damage.
- Product promotion is endless, our company will be dedicated to provide customers with better products.

9 Appendix

Revision history:

Date	REV.	Description	Page
2022.12.12	1.0	Original	8